



SAVAGE
BROS. CO.
S I N C E 1 8 5 5

1125 Lunt Avenue
Elk Grove Village, IL 60007-5023 USA



Phone: 847-981-3000
USA Fax: 800-2-SAVAGE
World Fax: +847-981-3010

E-mail: info@savagebros.com
Web: www.savagebros.com

A 21st Century Company . . . with 19th Century Craftsmanship

CHOCOLATE MOLDING WORKSTATION

**Temperer, Depositor and Vibrating Table
in single compact unit**

**All functions under
PLC Touch-Screen Control!**

FEATURES

- Fully Automatic Stainless Steel Chocolate Tempering Tank – ability to maintain temper for 6 hours or more
- Adjustable Volume Depositing Pump – up to 10-1/2 ounces / 300 grams per deposit stroke with easy PLC touch-screen volume adjustment.
- Vibrating work surface and heated molding grate with excess chocolate return to tank
- Water-jacketed depositing pipe to nozzle to maintain perfect temper from tank to mold
- Multi-nozzle depositing heads available to fit your molds – easy no-tool changeover
- All functions of tank, pump and vibration under PLC Touch-Screen Control – visually easy for operator to mold in perfect temper

MODELS

- 125LB / 55KG or 200LB / 90KG tempering tanks
- 110V or 220V 50/60 Hz
- Requires connection to water and drain (sink) and source of compressed air



Vibrating work surface

Center molding grate is heated with excess chocolate return to tank



Water-jacketed depositing nozzle & pipe

Adjustable stroke volume depositing pump
PLC Touch-Screen Control of all functions

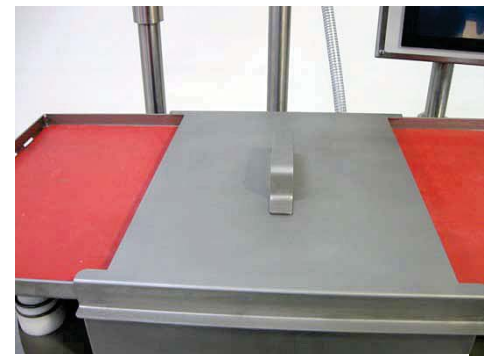

Handy cover over center molding section for idle periods

Entire work platform is easily removed from tank for cleaning



Gas & Electric Stoves ♦ Copper & Stainless Kettles ♦ Fire Maker Cooker-Mixers ♦ Carousel Line ♦ Bowl & Kettle Lift/Trucks ♦ Cooling Tables ♦ Chocolate Tempering ♦ Depositing & Transfer Systems

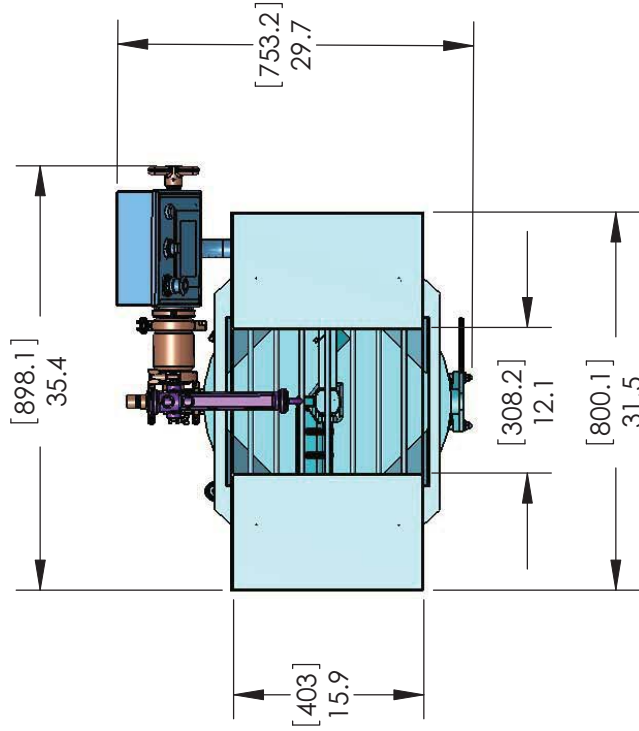

'A'

125LB = 37.3" [947]

200LB = 42.3" [1074]

UNITS: [MILLIMETERS]
INCHES

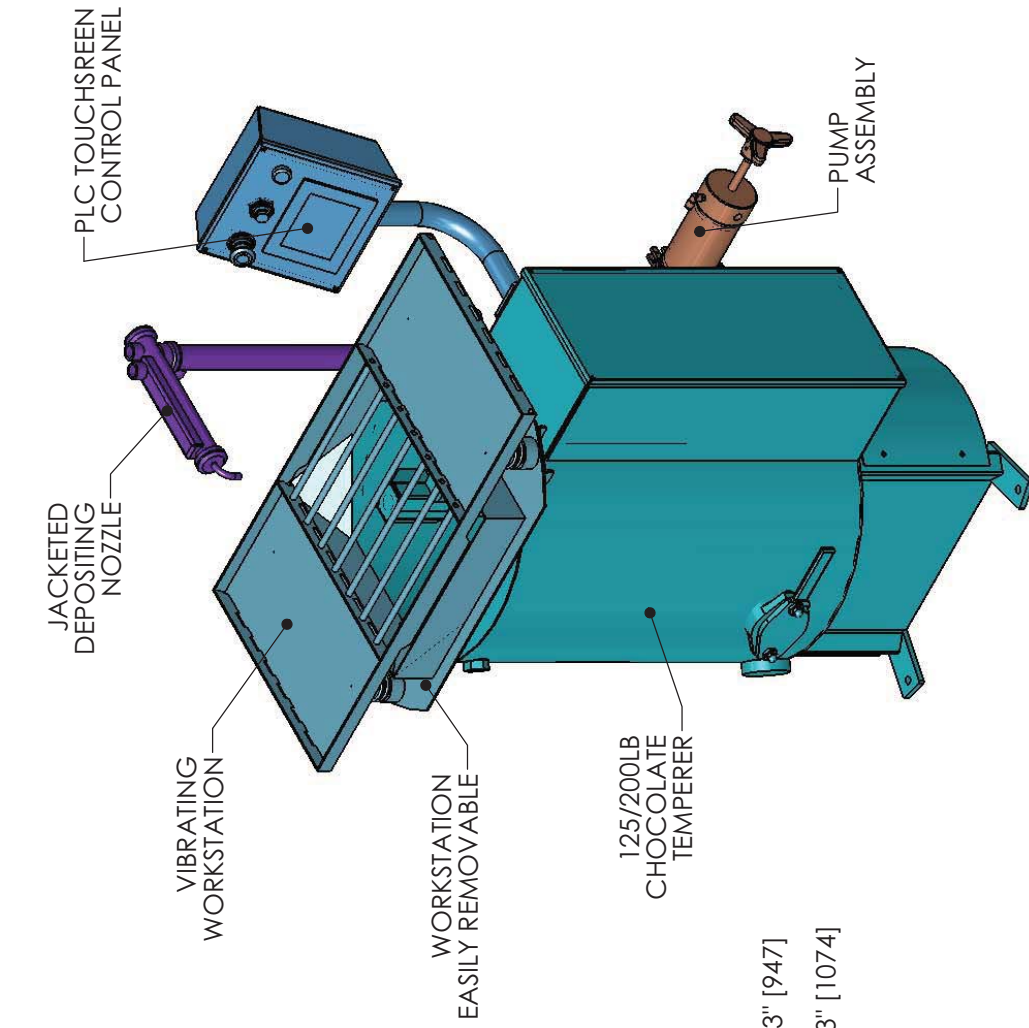

QUOTATION
FOR QUOTATIONAL PURPOSES
ONLY

ALL DESIGNS SUBJECT TO
FINAL APPROVAL BEFORE
MANUFACTURE

UNLESS OTHERWISE SPECIFIED
ALL DIMENSIONS ARE INCHES

DO NOT SCALE DRAWING



1125 W. Lunt Ave
Elk Grove Village, IL 60007 U.S.A.
Phone: (847) 981 - 3000
USA Fax: (800) 2 - SAVAGE
World Fax: (847) 981 - 3010

125/200LB CHOCOLATE TEMPERER
(CONTINUOUS) WITH WORKSTATION

DWG. NUM. SD-MOULDING_WORKSTATION

DRAWN BY

MP

DATE

02-13-09

SCALE

1:16

SHEET

1 OF 1