

Economiser



An economiser is a heat exchanger which utilizes the residual energy of the flue gases for heating of feed water. The economiser is the flue gas side connected between the steam boiler and the chimney. On the water side of the economizer between the boiler feed pump and the pressure element is connected. The water to be heated flows in counter-current to the flue gases to be cooled.

An economizer increases the efficiency of the steam boiler significantly and is recommended in any case.

At low condensate return (<25%), the economizer also be used to preheat the feed water in the feed water container. For this purpose, the water is pumped into the feed water container in the circulation of feed water container through the economizer again. Requires the steam boiler water, the circuit is interrupted and pumped the water from the economizer to the steam boiler. For this purpose, an optional Magnet valve with corresponding control is provided.

The optional on-demand switching of the economizer of the Kesselwasservorwärmung for circulation of feed water can lead to energy savings of up to 1%. The pump of the steam boiler pumped continuously. Requires the steam boiler no boiler water, feed water is pumped in circulation in the feed water container. This increases the flow in the economizer, the water temperature drops and thus increases the efficiency of the economizer.

A second economizer has a short payback time in many cases and is described in a separate section.

The second economizer

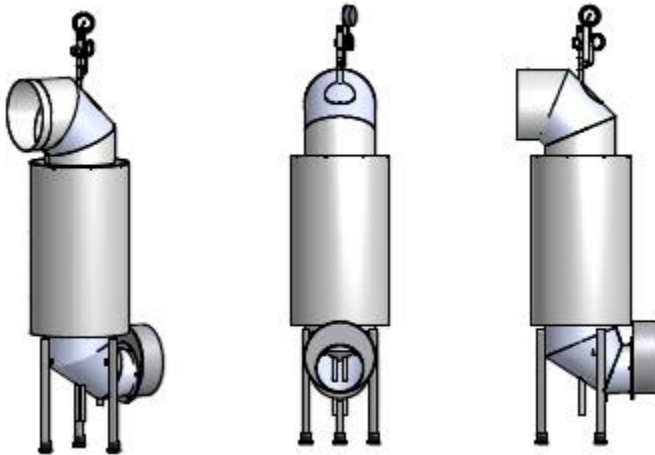

The second is a heat exchanger economizer, the use of the residual energy of the flue gases for heating water, such as:

- be supplied to the boiler feed water
- the feed water container to be supplied fresh, soft water
- Soft water for other applications

The second economizer flue gas side is connected between the first and the Economizer chimney.

The water to be heated flows in counter-current to the flue gases to be cooled. The lower the temperature of the flowing water, the higher the efficiency.

The inclusion of second economizer depends on the expected condensate return.

The reduced exhaust temperatures of the chimney draft and can not possibly be enough. The design of the chimney system should be recalculated accordingly. In case of brick chimneys, ie without stainless steel pipe is to be expected sooting.

Integration of the second economizer at little condensate return

With little condensate return (<50%), the second economizer should be included on the water side between the softener and the feed water container. Under optimum operating conditions and 0% condensate return the following services and exhaust gas temperatures are expected to:

steam boiler	Additional services
DG560	14-28kW
DG460	12-24kW / l
DG360	12-22kW / l
DG260	8-16kW / l

The appropriate design of the chimney is to observe due to the low exhaust temperatures. You may be a flue gas sucker to install.

Integration of the second economizer at much condensate return

In much condensate return (> 50%), the second economizer should be switched on the water side in series with the first economizer (between the boiler and the pump mounted on the boiler economizer). In this case, the economizer must be equipped with a safety valve, a pressure gauge and a water side economizer to the boiler shut-off valve. If the second economizer operated at about 90 ° C preheated

feed water at optimum operating conditions the following additional services and exhaust gas temperatures are expected to:

steam boiler	Additional services
DG560	8kW
DG460	7kW
DG360	7kW
DG260	5kW

Alternatively, the second economizer can water side with a circulating pump heat the feed water in the circuit and thus provide continuous heating of the feed water.

As another alternative, the second economizer can also be used for preheating of other water cycles - but only softened water may be heated.

Integration of the second economizer for multiple installations

For multiple installations are several steam boiler equipped with economizers and second is much condensate return available, the second economizer should be on the water side connected in series with the attached to the boiler economizers.

For multiple installations are several steam boiler equipped with economizers and second is little condensate return is present, the economizer should be switched on the water side in parallel and used to preheat the fresh water. It should be controlled by means of valves, that the fresh water flows only through the economizer, in which the burner of the associated steam boiler is running.

Alternatively, a Economiser be integrated water side between the softener and feed water container and the other second economizer should be included on the water side between the boiler pump and boiler-mounted economizer or used for circulation of feed water.