

## BREWHOUSE OPTIONS

### ORIENTATION:

- MASH LEFT/KETTLE RIGHT
- MASH RIGHT/KETTLE LEFT

### MASH SIDE MANWAY LOCATION:

- OPTION 1: Straight out side
- OPTION 2: Angled 45°

### HEAT SOURCE (TO BOILER):

- OPTION 1: Natural Gas
- OPTION 2: Propane

Steam Brewhouse Size	Capacity (gal)		Dimensions (inches)		
	Mash Tun	Boil Kettle	A (approx)	B (approx)	C (approx)
5	259	345	88	139	80
7	345	432	100	139	84.5
10	441	552	102	159	86
15	588	881	114	167	91
20	994	933	111	188	98.5
30	1147	1377	117	194	98.5

System	5 BBL (10 BBL HLT)	7 BBL (15 BBL HLT)	10 BBL (20 BBL HLT)	15 BBL (30 BBL HLT)	20 BBL (40 BBL HLT)	30 BBL (60 BBL HLT)
Weights (lbs)	3472	3635	4233	5153	6344	7500
Live (lbs)*	8742	12135	14773	21303	27424	33850

\*Live assumes Mash/Kettle/HLT all full to capacity (all weights are approximate)

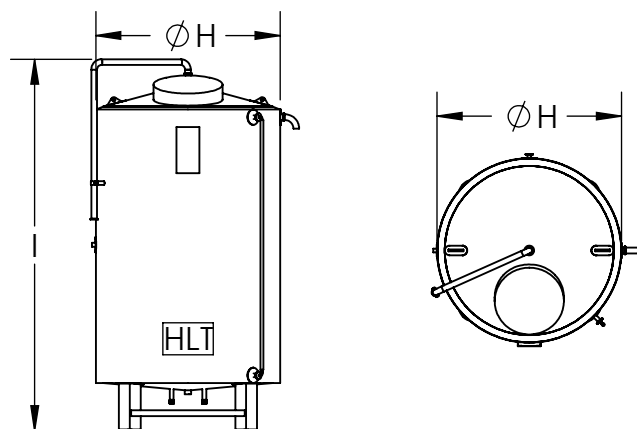

Steam HLT Size	HLT Capacity (gal)	Dimensions (inches)	
		H	I (approx)
10	316	48	78
15	474	48	102
20	620	54	103
30	936	61	116
40	1321	64	140
60	1903	76	142



## PKW STEAM LINEAR BREWHOUSE SPECS

BREWERY NAME: \_\_\_\_\_

- Approved
- Approved with Revisions
- Not Approved

Customer Signature \_\_\_\_\_ Printed Name \_\_\_\_\_ Date \_\_\_\_\_

**Office:** 503-236-4500  
**Fax:** 503-236-4513  
**Main Contact:** 503-314-7134 (Joe W)  
**Project Mgmt:** 971-803-1783 (Alex O)

**Main Contact:** Joe@Portlandkettleworks.com  
**Project Mgmt:** Alex@PortlandKettleWorks.com  
**Design:** Maggie@PortlandKettleWorks.com  
**Manufacturing:** Patrick@PortlandKettleWorks.com

[www.PortlandKettleWorks.Com](http://www.PortlandKettleWorks.Com)