

## 2.1 Pressure Glass Cover

up to 12/-1 bar

### Standard design

- Wetted material: 1.4571 or 1.4404  
attachment parts: 1.4301
- With Borosilicateglass, acc DIN 7080
- Plastic handle with stainless steel insert
- Silicone gasket
- With hinge and handle with plastic knob
- Neck length 150 mm, neck thickness 4 mm
- Surface unpolished, glass-bead blasted
- With approval (Modul G) acc. PED 97/23/Ec
- Design Code: AD-2000-Merkblatt



### Options

- Wetted materials: 1.4435 BN2, 1.4539, 1.4529, 1.4462, 1.4429, HC-22, HC-276, HC-2000, etc.
- Intermediate sizes
- Various gasket qualities
- Various surface qualities (glass-bead blasted, pickled or polished up to  $Ra < 0,2 \mu m$ )
- Neck length up to 2000 mm, neck thickness up to 20 mm
- Conical design of the neck (up to max. 8 mm neck thickness)
- Neck shaped to match tank-diameter
- Various handles: Stainless steel handle, toggle, nuts, etc.
- Cover side swiveling
- With wedge for side installation
- Locking pin in open position
- Spring assists (torsion-, disc-, or gasspring)
- Installation of various nozzle into the neck
- With various limit- or proximity-switches

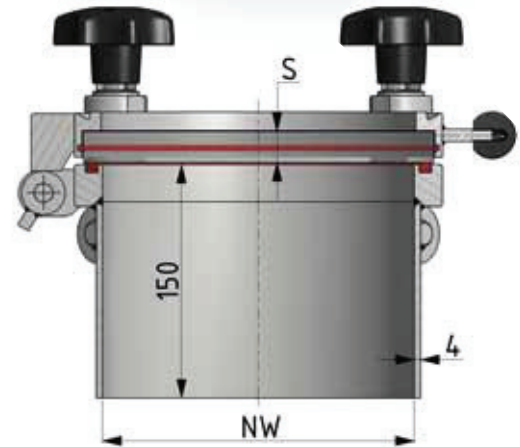

- With safety-grill or safety-cross
- With wiper and/or light
- With customer symbol blasted into the glass
- Attachment parts in other materials
- Various Design Codes: ASME VIII-1, EN13445, ...
- Optional with ASME-Approval Sec. VIII-1, latest Edition (additional surcharge, design-changes possible)

Article No.	NW	MAWP [bar]	zul. Betr. Temperatur [°C]	number of screws M16	size of glass pane (S) [mm]	Weight [kg]	Price in EUR
221 012	100	12	280	4	ø 125 x 20	14	
221 500	150	4	280	4	ø 175 x 20	15	
221 510	150	10	280	4	ø 175 x 25	17	
222 000	200	4	280	4	ø 225 x 20	18	
222 010	200	8	280	4	ø 225 x 25	19	
222 500	250	4	280	4	ø 275 x 25	25	
222 508	250	8	280	4	ø 275 x 30	26	
223 000	300	4	280	4	ø 325 x 25	29	
223 006	300	6	280	6	ø 325 x 30	30	
223 500	350	4	280	4	ø 375 x 30	34	
224 000	400	3	280	4	ø 425 x 30	39	
224 500	450	2,5	280	6	ø 475 x 30	43	
225 000	500	2	280	6	ø 525 x 30	48	
226 000	600	1	280	6	ø 625 x 30	61	

Gaskets see chapter 9.1 and 9.3 | glass-panes see chapter 8.7



**Zimmerlin GmbH**  
Edelstahl-Technik  
Frohmatenstr. 19  
D-79268 Bötzingen

Tel. +49(0)7663-6088-0  
Fax +49(0)7663-6088-88  
info@zimmerlin.de  
www.zimmerlin.de



Stand: Juni 2015