

NINON KONIC

**According to options machine outfitted with:****● MOTORIZED SLATE BAND CONVEYOR**

- Anodised aluminium profile, created by CDA; receiving an acetal slate band conveyor, width 82,5 mm ; double conveyor if required by the dimensions of the product to be labelled.
- Adjustable stainless steel guides, diameter 12mm, are adjustable to allow the passage of products up to 110mm diameter on single conveyor, 220 mm on double conveyor
- The motorised conveyor is built on a stainless steel frame, outfitted with blue side panels in which the electrics & electronics is integrated. It is built on wheels or on adjustable feet
- A pneumatic selection system is installed at the inlet of the conveyor, outfitted with one or two cylinders according to product size

According to required outfit:

- A square recollection table is installed at the outlet of the conveyor
- A transfer system is built at the end of the conveyor

● LABELLING

- One labelling station to apply labels on cone shaped plastic pails including:
 - One label dispenser built on a ball-and-socket joint enabling the adjustment of the label output angle.
 - The outfit that rotates the pail and applies the label especially adapted to its conicity
 - A special sensor to ensure the positioning of the label according to the handle
- The label dispensers are outfitted with asynchronous motors regulated by frequency converters
- All label dispensers are built on motorized up & down lifts to adjust the labelling height.
- The labelling height is adjusted through the digital display
- Label height from 8 to 300 mm
- Adjustment and memorizing of the label positioning through the digital display
- Label output speed: 13.4 meters per minute

● DIGITAL DISPLAY

- Validation zones
- Adjustment settings
- Bottle counter
- Label positioning
- Regulation of production rate and process timing
- Positioning memorizing – 50 positions
- Labelling height adjustment
- Process error detection and diagnosis



OPTIONS

- A detection cell to apply an additional label on already labelled products
- A vision camera to detect designs or shapes
- Additional conveyor length
- Ink jet lot marker
- Ultrasonic label detection sensor for transparent labels
- Front and back label from the same roll
- Clutched support plate for heavy label reels.
- Alarm light mast to notify dysfunctions
- Sensor to detect the end of the label roll
- Detection sensor to detect a missing label on the product to be labelled

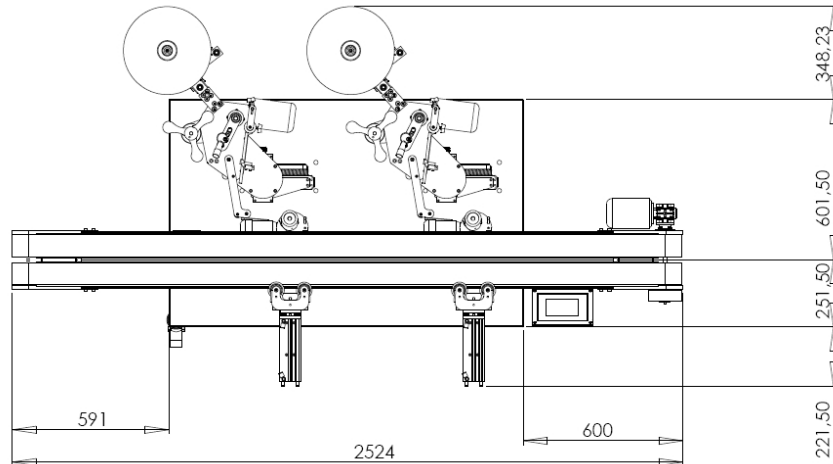

TECHNICAL DESCRIPTION	
Performance	According to the dimensions of product, label output speed : 13,4 m/min
Approximate weight in kgs	200 kgs
Machine width	1422 mm
Machine height	1300 mm
Machine length	2524 mm
Conveyor height	925 mm
Control	Digital Display
Absorbed power	2kw
Power supply	380 V ~ 50/60 Hz 16A 3 Phases + Neutral + Ground 16A
Air consumption	12 m3 / hour maxi at 6 bars – Dry air non lubricated
Ideal running temperature	From 10°C to 30°C

WINDING DIRECTION: LEFT OUT

Dimensions of the label rolls:

- A: inside diameter = 75mm
- B: Max. outside diameter = 260mm – 300 mm on request
- C: Max. band height = 160mm (higher on request)
- D: Space between labels = 3-5mm

Minimal paper quality: 90g

Nota: The rolls have to be stored in a dry place between 15°C and 18°C.

Machine delivered with EC Standards (non contractual documents)

