



Valve Concepts, Inc.

ISO Registered Company

Model 1049

Secure-Gard Pilot Operated Vent Valve

SECTION I

I. DESCRIPTION AND SCOPE

The Model 1049 Secure-Gard is a pilot operated vent valve intended for installation on atmospheric and low pressure storage tanks, vapor recovery systems, and process systems.



WARNING

The Model 1049 is a low pressure pilot operated valve. In as such, does not supply vacuum relief. If vacuum relief is required, it should be provided by a separate device.



CAUTION

Follow your company's safety procedures to avoid injury to personnel or damage to equipment.

SECTION II

II. PRIOR TO INSTALLATION

Remove all packing material inside and outside of the valve prior to installation.

SAFETY WARNING: In addition to your company's safety procedures, this section includes guidelines that should be followed during the installation, operation, and maintenance of Valve Concepts, Inc's Pilot Operated Vent Valve. It is necessary to completely read and understand these guidelines.

Tank or system over pressure protection is the primary function of pilot operated vent valves. It must be selected to meet the total pressure flow requirements within the Maximum Allowable Working Pressure of the system on which it is installed. Consult API Standard 2000 for tank protection sizing procedures. Improperly specified vent valves may result in structural damage to the tank or system, and may cause severe personal injury or death.

Valves are pre-set at the factory per customer purchase specifications. DO NOT change the set pressure without consulting the factory or your local VCI representative. Improper adjustment may cause the valve to malfunction.

DO NOT attempt to remove the valve from the tank or process vessel without first bleeding all pressure from the system. ALTERNATIVE MEANS OF PRESSURE VENTING MUST BE PROVIDED WHEN THE VALVE IS OUT OF SERVICE.

The valve has been exposed to process while in service. Observe all plant procedures and Material Safety Data Sheets (MSDS) for the products in the system while inspecting, adjusting, or servicing the valve. Take appropriate safety precautions regarding eye protection, respiration and skin contact.

SECTION III

III. INSTALLATION

The inlet and outlet flanges are normally standard ANSI 150 lbs. class flanges unless otherwise indicated and should be connected following accepted piping practices.

The inlet is vertical and the outlet is horizontal. The valve should be installed in the normal upright position with the cap at the top of the valve and the valve inlet at the bottom. The outlet is to the side.

For valves using the remote sensing port connection, sense lines should be a 1/2" O.D. tube or larger and the length should not exceed fifteen feet. Longer lengths may be used with larger diameter sense lines. The sense line should slope downward from the sense port to the tank to allow condensate, if any, to drain back into the tank and not block the sensing capability.

VALVES WITH PURGE ROTAMETER

For valves with a rotameter mounted for purging either the pilot sense line only or both pilot sense and discharge lines, connect the purge gas source, usually dry nitrogen, to the 1/4" FNPT connection at the bottom of the rotameter. The pressure of the purge gas source must be higher than the set pressure of the vent valve, but not to exceed the maximum pressure rating of the

rotameter. (Standard rotameter supplied by Valve Concepts is rated to 250 psig.) Once the gas source is connected, the purge flow can be adjusted by turning the knob at the top of the rotameter and observing the flow indicator. The purge mechanism is designed not to affect the set pressure of the vent valve.

When the tank pressure is below set pressure, the main valve seat will be closed. If the rotameter is mounted to purge both the pilot sense and discharge lines, there will be a very small flow to the valve outlet from the purge mechanism.

VALVE WITH AIR OR N2 ASSIST:

For valves with air or nitrogen assist pilot, connect the gas source to the 1/4" FNPT connection at the inlet of the filter regulator. The pressure must be a minimum of 5 psig, but not to exceed the maximum pressure rating of the filter regulator. (The standard filter regulator supplied by Valve Concepts is rated at 300 psig.)

INSTALLATION DIAGRAMS FOR STANDARD ACCESSORIES & CONFIGURATIONS

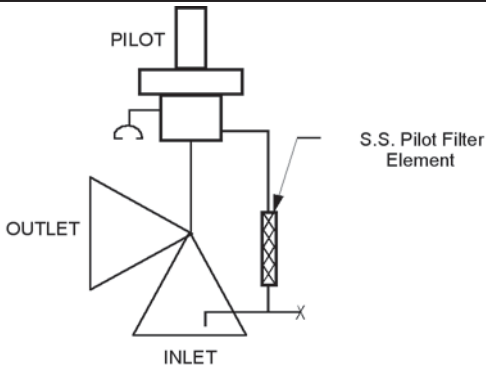

Standard Configuration
Internal Sensing, SS Pilot Filter Element and Pilot Exhaust to Atmosphere

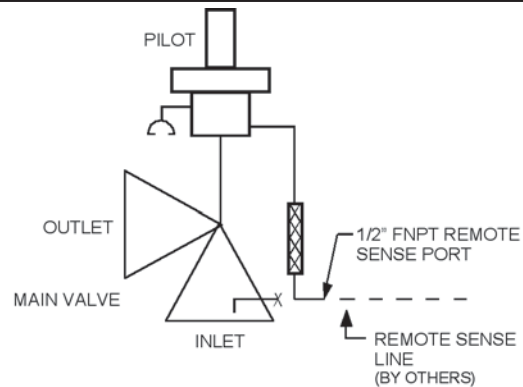

Option 2
With Remote Sensing

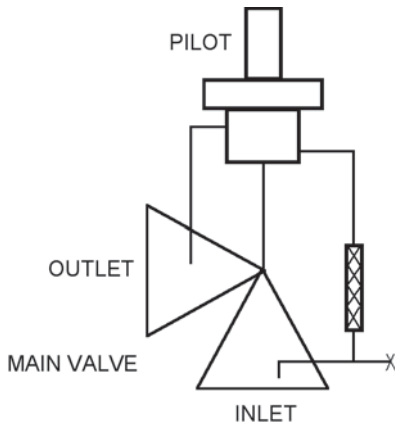

Option 1
With Pilot Exhaust Tubed to Main Valve Outlet

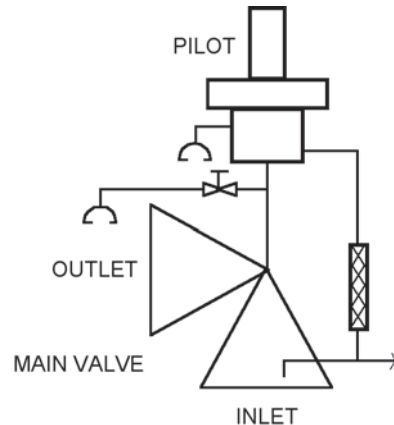

Option 3
With Manual Blowdown Valve

INSTALLATION DIAGRAMS FOR STANDARD ACCESSORIES & CONFIGURATIONS

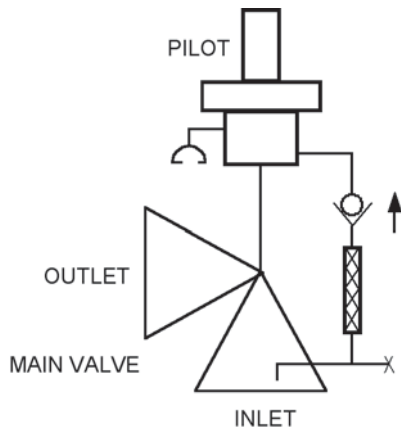

Option 4
With Back Flow Preventer to Prevent Back Flow through Main Valve and Pilot

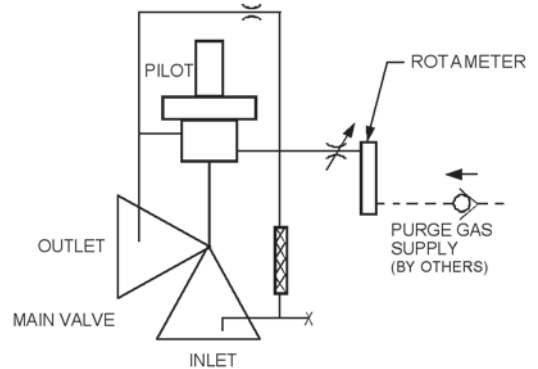

Option 7
With Rotameter to Purge Pilot Sense and Discharge Lines

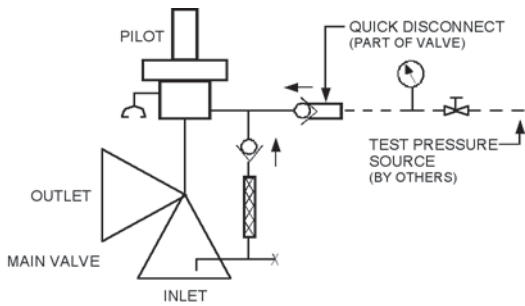

Option 5
With Field Test Connection (Back Flow Preventer Included)

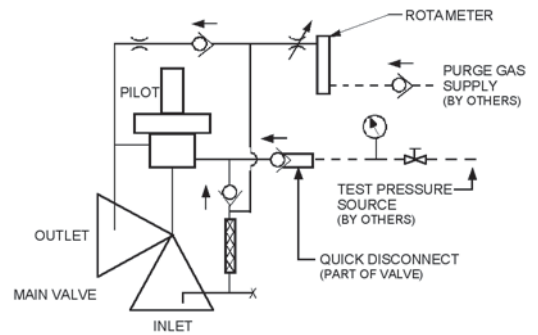

Option 8
With Field Test Connection, Back Flow Preventer and Rotameter to Purge Pilot Sense and Discharge Lines

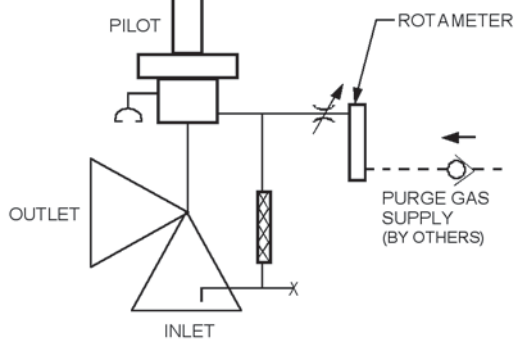

Option 6
With Rotameter to Purge Pilot Sense

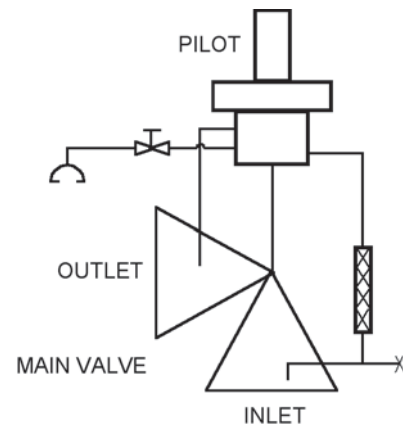

Option A
Internal Sensing, SS Pilot Filter Element, Pilot Exhaust to Main Valve Outlet with Manual Blowdown Valve

SECTION IV

IV. START-UP

Operation of the Model 1049 is automatic once the set pressure has been set. (The set pressure is bench-set per the customer's specified setting at the factory prior to shipment.) **NOTE:** The set pressure is defined as the pressure at which the valve should start to open on increasing tank pressure.

To adjust the set pressure, remove the hex cap at the top of the valve and loosen the jam nut around the adjusting screw. Clockwise rotation of the adjusting screw will increase the set pressure. Counter clockwise rotation will decrease the set pressure. Do not adjust the set pressure beyond the nameplate range. Tighten the jam nut after adjustments are made and replace the hex cap.

For the valve to be in the closed position, tank pressure must reach the actuator through the pilot.

Upon initial start-up, the valve may be opened for a few seconds, but will close when the pressure in the actuator chamber reaches tank pressure.

For valves with air or nitrogen assist pilot, the gas source must be connected to the filter regulator before the valve will be in the closed position. (The filter regulator is pre-set at the factory to 5 psig, and the CA-1 back pressure regulator is pre-set at the factory to 10 psig.)

SECTION V

V. MAINTENANCE

It is strongly recommended that if the valve needs to be serviced, that it be sent to the factory or a factory authorized repair facility. Trained mechanics with specialized test equipment will ensure that the valve is accurately set.

The Model 1049 should be periodically checked to ensure proper operation. The frequency required depends on the severity of the service conditions. At least once a year is recommended.

To disassemble the valve, refer to the appropriate drawings.

To replace soft goods of the pilot valve:

The pilot valve body maybe removed by unscrewing the item 131 nipple from the item 201 upper case weldment.

To disassemble the diaphragm case, relax the compressed spring by first unscrewing the item 105 cap, then loosen the item 114 jam nut and back off the item 113 adjusting screw. The ring of item 109 nuts, item 110 lockwashers, item 121 washer, and item 120 bolts around the periphery can now be removed. Remove item 120 bolts and item 110 lockwashers, holding items 104 spring bonnet and 102 upper diaphragm case together. Replace item 122 round gasket and reassemble items 102, 104, 110 and 120.

Remove item 115 set pressure spring, 112 spring button, and 134 ring gasket and set to the side. Hold the item

128 wrenching washers with a wrench, and loosen and remove item 109 nut. Remove items 110 lockwasher, 111 lower spring guide washers, 128 wrenching washers, 106 support plates, 107 diaphragm, 126 bolt gaskets, and 127 spacer and set to the side. Remove item 110 lock washer and item 120 bolt from item 101 pilot body and 103 lower diaphragm case. Remove items 124 seal diaphragm, item 125 body gasket and 108 spindle assembly. Take items 133 o-ring seat and item 126 bolt gasket off item 108 spindle assembly and replace with new parts.

Reinstall item 108 spindle assembly with items 133 o-ring and 126 bolt gasket. Set new item 124 seal diaphragm over the stem of the spindle assembly and item 125 body gasket on top of the item 124. Then, reinstall the item 103 lower diaphragm case to the item 101 pilot body with item 110 lock washer and item 120 bolt. Slide item 127 spacer over the stem of the spindle assembly and place another new item 126 bold gasket on top of the spacer. Place the first item 106 support plate on the stem, then the new item 107 diaphragm, then item 126 bolt gasket , then the final item 106 support plate. Place the items 128 wrenching washers, 111 lower spring guide washers, and 110 lockwasher on the stem. While holding the item 128 wrenching washers with a wrench, (and making sure the bolt holes of the diaphragm and diaphragm case align) thread the item 109 nut and tighten. Place items 115 set pressure spring and item 112 spring button on item 108 spindle assembly. Place new item 134 ring gasket on top of the item 107 diaphragm. Place the item 102 upper diaphragm case on top of item 103

lower diaphragm case. Instal items 121 washers, 120 bolts, 110 lockwashers, and 109 nuts and tighten.

Remove item 131 nipple from item 101 pilot body. Loosen item 114 jam nut. With needle nose pliers remove item 119 c-ring and unthread item 117 blowdown needle. Remove item 118 TFE o-ring. Place new item 118 TFE o-ring on item 117 blowdown needle. Reinstall in reverse order.

Thread the item 117 blowdown needle completely in, then back out 3 full turns, and lock the item 114 jam nut.

To replace soft goods of the main valve actuator:

Remove the items 208 washers, 205 bolts, 206 lockwashers, and 207 nuts. Lift pilot assembly off and set to the side. Replace item 203 actuator diaphragm. Reassemble in reverse order.

To replace soft goods of the main valve:

Remove the item 311 bolts and 310 lockwashers holding the item 202 cover/lower case weldment to the main body. Carefully remove the item 202 lower case weldment and item 307 cover gasket. Remove item 303 seat plate assembly and item 305 o-ring seat. Remove items 308 bolts and 309 lockwashers holding item 304 nozzle to item 301 body. Remove item 304 nozzle. Replace item 306 nozzle gasket. Reinstall item 305 o-ring seat into item 304 nozzle. Be sure the o-ring is completely in the nozzle, and that the exposed surface is flat. Bolt item 304 nozzle back into item 301 body with items 308 bolts and 309 lockwashers and tighten. Install item 303 seat plate assembly. Install new item 307 cover gasket and reinstall item 202 cover/lower case weldment with the item 310 bolts and item 311 lockwashers.

**TABLE 1
Soft Goods Kit Part Numbers**

Soft goods kits, consisting of all the non-metallic components (o-rings, sense diaphragm, gaskets, etc) are available. The drawings indicate which components are included in the kit. For other replacement parts, specify by item number and description plus material, if the part number is not known.

Always provide the model number, size if applicable, and the serial number when ordering kits/replacement parts.

Line Size	Spring Range	Soft Good Kit Numbers		
		O-RING MATERIAL		
		Buna-N	EPDM	Viton
2" x 3"	4" - 1.5 psig	31452033	31452055	31452044
	1.5 - 3 psig	31452933	31452955	31452944
	3.2 -14 psig	31452133	31452155	31452144
3" x 4"	4" - 1.5 psig	31453033	31453055	31453044
	1.5 - 3 psig	31453933	31453955	31453944
	3.2 -14 psig	31453133	31453155	31453144
4" x 6"	4" - 1.5 psig	31454033	31454055	31454044
	1.5 - 3 psig	31454933	31454955	31454944
	3.2 -14 psig	31454133	31454155	31454144
6" x 8"	4" - 1.5 psig	31456033	31456055	31456044
	1.5 - 3 psig	31456933	31456955	31456944
	3.2 -14 psig	31456133	31456155	31456144
8" x 10"	4" - 1.5 psig	31458033	31458055	31458044
	1.5 - 3 psig	31458933	31458955	31458944
	3.2 -14 psig	31458133	31458155	31458144
10" x 12"	4" - 1.5 psig	31451033	31451055	31451044
	1.5 - 3 psig	31451933	31451955	31451944
	3.2 -14 psig	31451133	31451155	31451144
12" x 16"	4" - 1.5 psig	31459033	31459055	31459044
	1.5 - 3 psig	31459933	31459955	31459944
	3.2 -14 psig	31459133	31459155	31459144

SECTION VI

VII. TROUBLE SHOOTING GUIDE

1. Model 1049 opens below set point.

Possible Cause	Remedy
A. Sense line is clogged.	A1. Check sense line and sense port for blockage. Clean as needed
B. Incorrect set pressure.	B1. Adjust set pressure screw to proper set pressure.
C. Pilot or actuator diaphragm failure.	C1. Disassemble and check diaphragms. Replace if required.
D. Loss of external air/N2 source for air/N2 assist pilot.	D1. Check external source.

2. Model 1049 will not open.

Possible Cause	Remedy
A. Incorrect set pressure.	A1. Adjusting set pressure screw to proper set pressure.
B. Pilot exhaust plugged.	B1. Check pilot exhaust for blockage. Clean as needed.
C. Sense line clogged.	C1. Check sense line and sense port for blockage. Clean as needed.

3. Vapor leaking from pilot spring bonnet.

Possible Cause	Remedy
A. Pilot diaphragm failure.	A1. Disassemble and check pilot diaphragm. Replace if required.

4. Seat Leakage

Possible Cause	Remedy
A. O-ring seat has failed.	A1. Disassemble and check o-ring seat. Replace if required.
B. Foreign particles trapped between seat and seat plate.	B1. Check and clean as needed.
C. Sense line clogged.	C1. Check sense line and sense port for blockage. Clean as needed
D. Back pressure higher than tank pressure.	D1. Vent operating properly.

Model 1049 Pilot Assembly

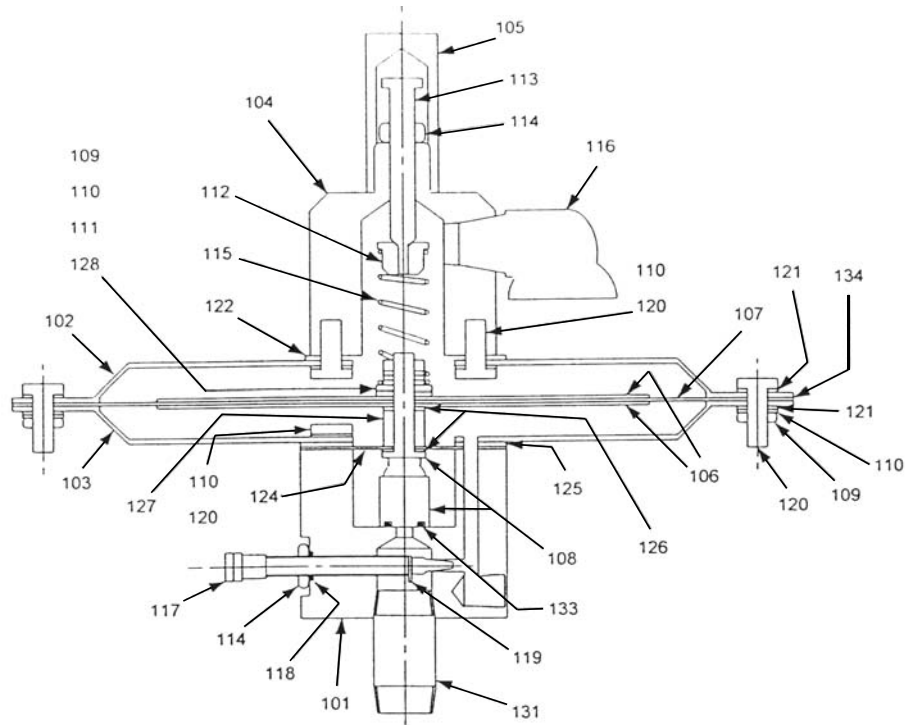

<u>ITEM NO.</u>	<u>QUANTITY</u>	<u>PART NAME</u>
101	1	Pilot Body
102	1	Upper Diaphragm Case
103	1	Lower Diaphragm Case
104	1	Spring Bonnet
105	1	Cap
106	2	Support Plate
107‡	1	Diaphragm
108	1	Spindle Assembly
109	17	Nut
110	20	Lockwasher
111	2	Lower Spring Guide Washer
112	1	Spring Button
113	1	Adjusting Screw
114	2	Jam Nut
115	1	Set Pressure Spring
116	1	Bug Screen Vent
117	1	Blowdown Needle
118‡	1	O-Ring - TFE
119	1	C-Ring
120	20	Bolt
121	16	Washer
122‡	1	Round Gasket
124‡	1	Seal Diaphragm
125‡	1	Body Gasket
126‡	3	Bolt Gasket
127	1	Spacer
128	2	Wrenching Washer
131	1	Nipple
133‡	1	O-Ring Seat
134‡	1	Ring Gasket

‡Parts are included in the Soft Goods Kit

Model 1049 Main Valve Body & Actuator

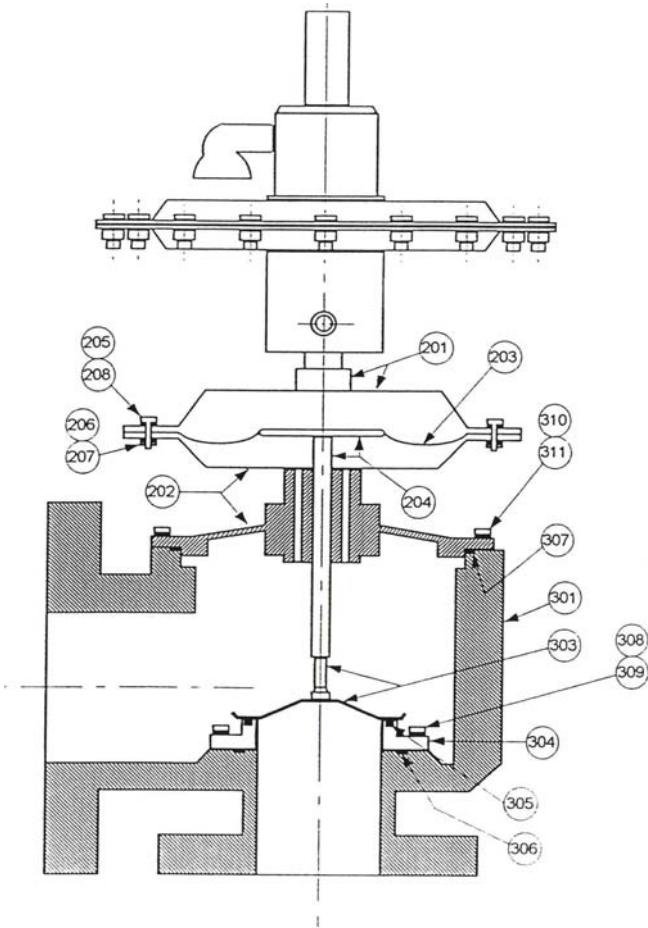

ITEM NO.	QUANTITY	PART NAME
201	1	Upper Case Weldment
202	1	Cover/Lower Case Weldment
203 ‡	1	Actuator Diaphragm
204	1	Support Plate Weldment
205	16	Bolt
206	16	Lockwasher
207	16	Nut
208	16	Washer
301	1	Body
303	1	Seat Plate Assembly
304	1	Nozzle
305 ‡	1	O-Ring Seat
306 ‡	1	Nozzle Gasket
307 ‡	1	Cover Gasket
308	6	Bolts
309	6	Lockwashers
For 2" x 3" Size Only		
310	6	Bolts
311	6	Lockwashers
For 3" x 4" Size Only		
310	8	Bolts
311	8	Lockwashers
For 4" x 6" Size Only		
310	8	Bolts
311	8	Lockwashers
For 6" x 8" Size Only		
310	8	Bolts
311	8	Lockwashers
For 8" x 10" Size Only		
310	12	Bolts
311	12	Lockwashers
For 10" x 12" Size Only		
310	16	Bolts
311	16	Lockwashers
For 12" x 16" Size Only		
310	16	Bolts
311	16	Lockwashers

‡Parts are included in the Soft Goods Kit

Valve Concepts, Inc.
 3644 Westchase Drive
 Houston, TX 77042-5224
 PH (713) 271-7171
 Fax. # (713) 271-0153
 www.valveconcepts.com
 email: vcisales@cashco.com
 Printed in U.S.A. Model 1049 IOM