



MODEL DA5

APPLICATIONS

“DO-ALL” concept allows application of all types of clean fluids. Designed primarily as a gaseous service valve, can be applied in liquid service applications where excessive cavitation or flashing is absent. Excellent for atmospheric industrial gases – GN₂, GOX, Ar, He, H₂, CO₂ – as well as a natural gas back pressure regulator. Used as a utilities – air, oil, water, steam – back pressure regulator. Corrosive and non-corrosive chemical services – gas or liquid – are possible with broad materials range. Special variations available for cryogenic gas or liquid service.



CAUTION

This is not a safety device and must not be substituted for a code approved pressure safety relief valve or rupture disc.

MODEL DA5

DO-ALL SERIES V BACK PRESSURE REGULATOR Spring Operated: 1/2" – 4" (DN15 - 100)

The Model DA5 is a high performance, spring operated, back pressure regulator with top-guided piston-cylinder that provides high flow capacity and high pressure drop capability. Internal trim design allows the same basic unit to cover a broad range of pressure settings. Performance approaches that of competitive pilot-operated designs in the basic design. Applied primarily in clean gaseous service, but also can be applied as a liquid or steam valve.

FEATURES

- Versatile:** Five basic materials and multiple trim material combinations to select from.
- Tight Shutoff:** Multiple composition materials provide Classes II, IV or VI inboard leakage rates. Designed as a soft-seated valve.
- Capacity:** Highest in the industry. Allows smaller body sizes than competitors in majority of applications.
- Pressure Drop:** Highest in the industry when coupled with high flow capacity.
- Trim Design:** “DO-ALL” trim design provides FTO flow direction. Results in high sensitivity and stability. Internals are cage-contained within easily removable quick change trim.
- Rangeability:** Basic valve gives outstanding rangeability due to close tolerances, balanced trim, and a broad range of elastomeric diaphragms and soft seats. Can be as high as 500:1.
- Heavy-Duty Guiding:** Heavy top guided to maintain stability and increased diaphragm life.

STANDARD / GENERAL SPECIFICATIONS

Body/Spring Chamber Materials

DI/DI	BRZ/CS	HC/CS *
CS/DI	BRZ/SST	HC/SST *
CS/CS	SST/DI	Dup SST/CS
BRZ/BRZ *	SST/CS	Dup SST/SST
BRZ/DI	SST/SST	Dup SST/Dup SST

* Through 2" (DN50) body size only.

DI = Ductile Iron CS = Carbon Steel BRZ = Bronze
 SST = Stainless Steel HC = Hastelloy C
 Dup SST = Super Duplex SST

Body Sizes

1/2", 3/4", 1", 1-1/4", 1-1/2", 2", 2-1/2", 3", 4"
 (DN15, 20, 25, 32, 40, 50, 65, 80, 100)

End Connections

Standard: Female NPT (screwed).
ASME Flanged: 125#, 150#, 250#, 300#, 600#;
DIN Flanged: PN16, PN25, PN40;
 (Integral Flanged Body unless listed under Opt.-30)
 Opt-31: British Standard Pipe Threads
 Opt-32: Schedule 80 Extended Pipe Nipples.
 Opt-34: 14" Face to Face Flange Dimension.
 Opt-41: Extension Tube Ends.

Recommended Max. Useable Cv

Body Size		Diaphragm		Body Size		Diaphragm	
in	(DN)	Comp. Cv	Metal Cv	in	(DN)	Comp. Cv	Metal Cv
1/2"	(15)	3.6	2.6	2"	(50)	51	10.2
3/4"	(20)	7.2	2.6	2-1/2"	(65)	76.5	N/A
1"	(25)	12.7	3.0	3"	(80)	108	N/A
1-1/4"	(32)	20.7	5.1	4"	(100)	187	N/A
1-1/2"	(40)	25.5	5.1	-	-	-	-

See Table DAG-7 for Wide Open Cv Limits.
 See Tables 3A through 3D and 4A through 4C for Cv
 vs. Droop vs. Range Spring tables.

METRIC CONVERSION FACTOR: $C_v / 1.16 = k_v$

Inlet Pressure Range

Operating: 1–675 psig (.07-46.5 Barg).
 See Tables DAG-1A – 1H for design P vs. T limits.

Pressure Drop Limits

3–675 psid (.21-46.5 Bard)
 Function of service fluid, base trim material, diaphragm and
 dynamic seal design. See Table 2 and DAG-2, DAG-3
 & DAG-4

Temperature Range

-425° to +400°F (-254° to +204° C)
 Limited by body/sp.ch. material combinations, and by
 elastomeric – diaphragm, seat, static seal, dynamic
 seal – materials. See Tables DAG-1A through 1H and
 Table DAG-5.
Alternate "CS" Mat'l - Steel - ASTM A352 Gr. LCC -
 Minimum temperature -50 °F (-46 °C).
Cryogenic Application see Opt -5 or -36.

Inboard Leakage Rates

See Table DAG-10

Optional Constructions

- Opt-5: Cryogenic Const.
- Opt-9: *TFE Diaph. Cover
- Opt-25: 1/4" (DN8) NPT Tap Spring Chmb.
- Opt-25S: Vent Screen
- Opt-30: Weld-on Flanges
- Opt-32: Ext. Pipe Nipples
- Opt-34: 14" F to F Flange
- Opt-36: Cryogenic Const.
- Opt-40: NACE Const.
- Opt-41: Ext. Tube Ends
- Opt-55: Oxygen Cleaned
- Opt-56: Special Cleaned
- Opt-57: Chlorine Cleaned
- Opt-80: High Inlet Press.
- Opt-85: Extra Set Press. Taps
- Opt-95: Epoxy Paint
- Opt-95OS: Epoxy Paint

* Available with Composition Diaphragm ONLY.

ABBREVIATIONS		
FK = Fluorosilicone	NBR = Buna-N	PTFE = Polytetrafluoroethylene
FKM = Fluorocarbon Elastomer	RTFE = Brz-fill TFE	V-TFE = Virgin TFE
EPR = Ethylene Propylene	GF-TFE = Glass-fill TFE	CTFE = Chlorotrifluoroethylene
BC = Neoprene	PA = PolyAll	3-ply (PTFE+FKM+PTFE)

MATERIAL SPECIFICATIONS

Body

- DI – ASTM A395
- CS – ASTM A216, Grade WCB
 Alternate ASTM A352 Gr. LCC
- BRZ – ASTM B62, Alloy 83600,
- SST – ASTM A351, Grade CF3M.
 Alternate ASTM A995/A995M7 Gr. 6A
- HC – ASTM A494, Gr. CW-12 MW.

See DAG-1A through DAG-1H for material specs.

Spring Chamber

- DI – ASTM A395
- CS – Sizes 1/2" - 4" ASTM A216, Gr. WCB;
 Alternate ASTM A352 Gr. LCC
 Opt-80 - Sizes 1/2"-1-1/2" ASTM A516, Gr. 55,
 ASTM A106, Gr. B; Size 2" ASTM A216, Gr. WCB
- BRZ – ASTM B62, Alloy 83600.
- SST – Size 1/2" - 4" ASTM A351 Gr. CF3M;
 Opt-80 - Size 1/2" - 1-1/2" ASTM A312, Gr. 316L,
 ASTM A479, Gr. 316L; Size 2" is ASTM A351 Gr. CF3M
 Alternate ASTM A995/A995M7 Gr. 6A

Diaphragm *

- Elastomeric – BC, EPR, FKM, FK, NBR, FKM+TFE,
 3-ply (PTFE+FKM+PTFE).
- Metallic – Be-Cu. (only 1/2" - 2" sizes)

Metallic Trim *

17-4PH SST, 316L SST, Nickel-Copper Alloy (Monel[†]),
See Table 2A

Seat *

PolyAll, V-TFE, GF-TFE, CTFE, FKM

Static Seals (See Fig. DAG-F1) *

- RTFE, NBR, FKM, FK, EPR, (All Sizes)
- SST/TFE (1/2" - 2") (DN15 - 50)
- V-TFE (2-1/2" - 4") (DN65 - 100)

Dynamic Seals (See Fig. DAG-1) *

- Type CP – TFE cap+ NBR, FKM, FK, EPR o-ring seal.
- Type UC – V-TFE u-cup seal w/ 316L SST energizer
 – V-TFE u-cup seal with Elgiloy energizer
 – V-TFE u-cup seal with Hast-C energizer
- Type PR – GF-TFE piston ring assembly seal with
 17-7PH SST energizer.

Painting

Standard: All non-corrosion resistant portions to be painted with corrosion resistant epoxy paint per Cashco Spec #S-1606.

Alternate: See Opt-95 or Opt-95OS

* See Product Coder for acceptable combinations.

† Monel[™], and Inconel[®] are registered trade names: Monel[™] is a mark owned by International Nickel Co. Inconel[®] is a mark owned by International Nickel Co.

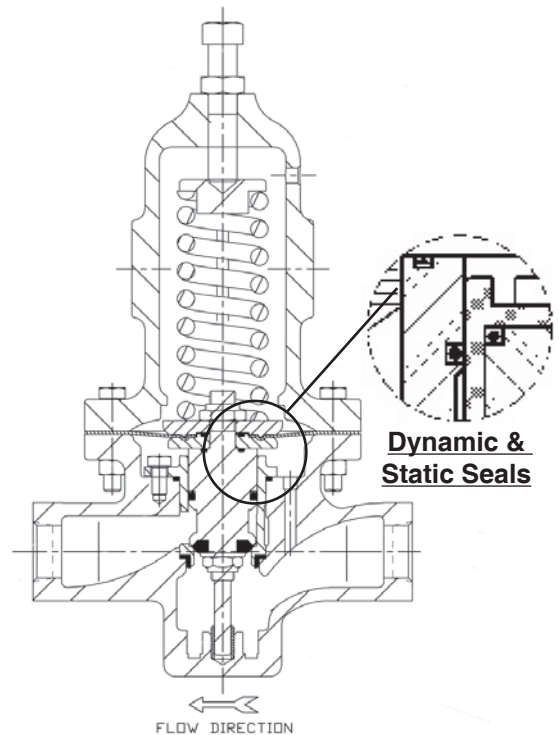

**Reverse Flow Direction
Composition Diaphragm
FTO – Flow-to-Open
Balanced at Outlet**

FIGURE 1 – Model DA5

OPTION SPECIFICATIONS

OPT-5: **BRZ CRYOGENIC CONSTRUCTION.** BRZ/BRZ body/spring chamber materials. NPT end connections. SN & TN trim selections only. Drilled condensate drain hole. **Select Opt-55 or Opt-56 for Special Cleaning.** Applicable temperature range -325° to +150° F. (-198° to +66° C). Design requires that spring chamber be mounted pointed downwards in a horizontal pipe.

OPT-9: **TFE DIAPHRAGM COVER.** A 0.020" (0.5 mm) thick TFE diaphragm is added to the selected diaphragm. TFE diaphragm cover is exposed to process fluid, providing added chemical compatibility. Use with composition diaphragm only.

OPT-25: **SPRING CHAMBER VENT TAP.** A 1/4" (DN8) - FNPT tap is located on spring chamber to allow for remote venting in case of diaphragm rupture. Primarily used when handling toxic or flammable fluids.

OPT-25S: **VENT SCREEN.** Cap (includes OPT-25).

OPT-30: **WELDED FLANGED CONNECTIONS.** CS, SST or HC body materials only. 1/2"-2" (DN15-50) body sizes only (no 1-1/4" (DN32) size). Welded-on flange of same general chemistry as body. See Opt-34 for special 14" face to face dimension.

Weld-On Flanges		
Sizes	Body Material	ASME Pressure Class
1/2" - 3/4"	CS, SST	150, 300, 600
1"	CS, SST	600
1", 1-1/2" - 2"	HC	150, 300
Sizes	Body Material	ISO Pressure Class
DN15-50	CS, SST	PN40 RF
DN65-100	CS, SST	PN16, 25, 40 RF

NOTES: 1. The body P vs. T ratings are the limiting variables for flanged end connections, unless further restricted by ASME B16.5.

2. No post-weld stress relieving performed.

OPT-31: **BSP END CONNECTIONS.** British Standard Pipe threads per ISO 7/1; used as an alternate to NPT ends. 1/2" - 2" (DN15-50) sizes only.

OPT-32: **EXTENDED PIPE NIPPLES.** Sch. 80 extension pipe nipples available for CS and SST bodies; for body sizes 1/2"-2"(DN15-50)only.

OPT-34: **SPECIAL 14" FACE TO FACE DIMENSION FOR FLANGED END CONNECTIONS.** Sizes 1/2" - 1" & 1-1/2" only. See Opt.-30 for standard face to face dimension.

OPT-36: Same specification as Opt-5 except for SST/ SST body/spring chamber materials. (Be-Cu diaphragm material.)

OPT-40: **NACE CONSTRUCTION.** Internal wetted portions meet NACE Std. MR0175; for application in sour gas/crude service. Exterior of unit to not be directly buried, insulated, or otherwise denied direct atmospheric exposure. CS/CS, LCC/LCC, LCC/SST, SST/CS, or SST/SST body/spring chamber materials only. 316L SST trim materials only. ELG/TFE U-cup dynamic seals. Available in all end connections. All welded portions heat treated to stress relieve weldments.

OPT-41: **EXTENDED TUBE END CONN.** SST body material only. Body sizes 1/2"-1" (DN15-25), 1-1/2" & 2" (DN40-50) only. SST extension tubes are welded to body, ending in tube diameters with 0.065 inch wall thickness. **NOT FOR HIGH PURITY REQUIREMENTS.**

OPT-55: **SPECIAL CLEANING - GOX.** BRZ or SST body materials only. Cleaning, assembly and packaging per Cashco Spec No. S-1134, making unit suitable for Oxygen Service. **NOTE: Design Pressure Rating shall not exceed 375 psig (25.8 Barg) when body material is SST and process medium is oxygen.**

OPT-56: **SPECIAL CLEANING.** Cleaning per Cashco Spec. No. S-1542 for all body/spring chamber materials. Higher cleaning level than std. commercial cleaning. **NOT suitable for Oxygen Service.**

OPT-57: **SPECIAL CLEANING - Cl₂.** CS, SST, or HC body materials only. Cleaning per Cashco Spec. #S-1589. For chlorine gas/liquid service.

OPT-80: **HIGH INLET PRESSURE.** Applies only to body sizes 1/2"-2" (DN15-50). Selecting highest available range spring requires special spring chamber construction. Only available with CS or SST spring chamber materials. Trims of P2, P3, P7, PJ, M7, M9, NP, NV, T7 or T9 only.

OPT-85: **PRESSURE TAPS.** Provides **second set** of inlet and outlet 1/4" (DN8) - FNPT taps with plugs (same basic material as body) on backside of body. Includes second external sensing port tap. See page 21 for details on tap location for both STD. and Opt -85. **NOTE:** Not available for HC body.

OPT-95: **EPOXY PAINT.** Special epoxy painting of all

non-corrosion resistant external surfaces per Cashco Spec. No. S-1547. Utilized in harsh atmospheric conditions.

OPT-950S: EPOXY PAINT. Special epoxy painting of all non-corrosion resistant external surfaces per Cashco Spec. No. S-1687. Utilized in OFFSHORE atmospheric conditions.

TECHNICAL SPECIFICATIONS

Body Size in. (DN)	Spring Range psig	Body Size in.	Spring Range psig
1/2", (15) 3/4", (20) 1" (25)	1-5 *	2" (50)	1-5 *
	1-10 *		1-10 *
	5-20 **		5-15 **
	10-35		10-30
	20-80		15-50
	30-150		30-90
	70-200		50-150
	100-300		80-225
	200-450 (Opt-80) ✓		80-275 (Opt-80)✓
			1-10 *
1-1/4", (32) 1-1/2" (40)	1-5 *	2-1/2", (65) 3", (80) 4" (100)	5-20 **
	1-10 *		10-40
	5-20 **		10-70
	15-45		40-125
	10-70		50-225
	40-175		
	70-200		
	100-350		
	100-400 (Opt-80) ✓		

* Composition diaphragm construction ONLY.

** Metal diaphragm for set point pressures \geq 5 psig (.34 Barg).

✓ OPT-80 requires selection of a CS or SST spring chamber.

METRIC CONVERSION: psig / 14.5 = Barg.

**TABLE 2
MAXIMUM DIAPHRAGM RATING**

NOTE: The below ratings may be further "derated" by limitations thru the Pressure Equipment Directive (97/23/EC-May '97).

Diaphragm Material	Standard Diaphragm Construction psig (Barg) *	
	Body Size in (DN)	
	1/2" - 2" (15-50)	2-1/2" - 4" (65-100)
BC, EPR	1250 (86.1)	800 (55.1)
NBR	450 (31.0)	300 (20.6)
FKM, FKM+TFE, FK	700 (48.2)	550 (37.9)
3-ply (PTFE+FKM+PTFE) **	125 (8.6)	125 (8.6)
Metal (Be-Cu)	1500 (103)	N/A

*Maximum setting of pressure safety device – safety relief valve or rupture disc.
 ** For Steam applications.
 NA = Not Available

**TABLE 2A
METALLIC TRIM MATERIAL COMBINATIONS**

PART	TRIM DESIGNATION				
	P	H	M	S	T
Plug	17-4 PH SST	Hastelloy-C	Monel†	316L SST	17-4 PH SST
Guide Bearing	17-4 PH SST	Hastelloy-C	Monel†	316L SST	17-4 PH SST
Cage	316L SST	Hastelloy-C	Monel†	316L SST	Monel†
Body Bushing	17-4 PH SST	Hastelloy-C	Monel†	Monel†	Monel†

† See Page 3 for registered trade name information.

**TABLE 3A
FULL PORT FLOW CAPACITY – Cv
COMPOSITION DIAPHRAGM
F_L = 0.90**

Pressure Setpoint Psp psig	Cv Capacity @ % Build															Range Spring psig
	BODY SIZE 1/2" (DN15)					BODY SIZE 3/4" (DN20)					BODY SIZE - 1" (DN25)					
	10%	20%	30%	40%	50%	10%	20%	30%	40%	50%	10%	20%	30%	40%	50%	
1	0.92	1.22	1.43	1.62	1.8	1.15	1.75	2.38	2.97	3.53	1.28	2.34	3.4	4.4	5.34	1-5
3	2.67	2.77	2.91	3.03	3.16	3.44	3.95	4.85	5.7	6.5	3.83	5.27	6.93	8.49	9.95	
5	3.52	3.54	3.56	3.58	3.6	4.97	7.14	7.16	7.18	7.2	5.53	9.6	12.7	12.73	12.75	
1	0.44	0.6	0.69	0.78	0.86	0.56	0.86	1.15	1.42	1.67	0.6	1.11	1.72	2.29	2.83	1-10
5	2.64	2.59	2.81	3	3.19	2.8	4.9	6.5	7.18	7.2	3.66	5.1	6.67	8.15	9.54	
10	3.52	3.54	3.56	3.58	3.6	4.76	7.14	7.16	7.18	7.2	5.23	9.15	12.1	12.73	12.75	
5	1.84	2.14	2.19	2.24	2.29	2.3	4	5.3	6.3	7.05	2.55	4.08	5.23	6.31	7.32	5-20
10	2.91	3.54	3.56	3.58	3.6	3.64	6.4	7.16	7.18	7.2	4.04	6.59	8.67	10.6	12.5	
15	3.52	3.54	3.56	3.58	3.6	4.4	7.14	7.16	7.18	7.2	4.89	9.1	11.3	12.73	12.75	
20	3.52	3.54	3.56	3.58	3.6	6.39	7.14	7.16	7.18	7.2	7.1	12.4	12.7	12.73	12.75	
10	0.88	1.25	1.52	1.78	2.02	1.11	1.79	2.53	3.24	3.9	1.23	2.38	3.61	4.77	5.86	10-35
20	1.96	2.68	3.05	3.4	3.6	2.45	3.83	5.09	6.28	7.2	2.72	5.1	7.27	9.3	11.2	
30	3.18	3.54	3.56	3.58	3.6	3.98	5.87	7.16	7.18	7.2	4.42	7.82	10.3	12.1	12.75	
35	3.4	3.54	3.56	3.58	3.6	4.59	6.9	7.16	7.18	7.2	5.1	8.5	11.1	12.73	12.75	
20	0.67	0.99	1.16	1.33	1.49	0.84	1.4	1.94	2.44	2.91	0.94	1.87	2.76	3.6	4.39	20-80
40	1.13	1.83	2.32	2.78	3.22	1.42	2.62	3.87	5.04	6.15	1.57	3.49	5.53	7.44	9.25	
60	2.39	3.24	3.56	3.58	3.6	2.98	4.62	6.07	7.18	7.2	3.32	6.16	8.67	11	12.17	
80	3.33	3.54	3.56	3.58	3.6	4.17	5.5	6.5	7.18	7.2	4.63	8.1	10.7	12.6	12.75	
30	0.61	0.89	1.07	1.24	1.4	0.77	1.28	1.79	2.26	2.72	0.85	1.7	2.55	3.35	4.1	30-150
50	1.07	1.56	1.79	1.99	2.19	1.34	2.24	2.98	3.67	4.32	1.49	2.98	4.25	5.45	6.58	
75	1.84	2.46	2.75	3.02	3.27	2.3	3.51	4.58	5.59	6.53	2.55	4.68	6.55	8.3	9.96	
100	2.33	3.13	3.56	3.58	3.6	2.91	4.46	5.65	6.77	7.2	3.23	5.95	8.08	10.1	12	
125	3.06	3.54	3.56	3.58	3.6	3.83	5.58	6.8	7.18	7.2	4.25	7.44	9.8	11.6	12.75	
150	3.37	3.54	3.56	3.58	3.6	4.21	6.2	7.16	7.18	7.2	5.1	8.9	11.7	12.73	12.75	
70	0.46	1	1.39	1.76	2.11	0.58	1.44	2.32	3.15	3.93	1	2	3	4	5	70-200
100	1.47	2.12	2.41	2.69	2.96	1.84	3.03	4.02	4.96	5.83	2.04	4.04	5.74	7.34	8.84	
125	1.99	2.72	3.03	3.33	3.4	2.49	3.89	5.06	6.15	6.8	2.76	5.19	7.23	9.14	10.9	
150	2.33	3.21	3.56	3.58	3.6	2.91	4.59	5.53	6.42	7.2	3.23	6.12	7.91	9.58	11.2	
175	2.85	3.54	3.56	3.58	3.6	3.56	5.68	6.74	7.18	7.2	3.95	7.57	10.3	12.34	12.75	
200	3.4	3.54	3.56	3.58	3.6	4.28	7.14	7.16	7.18	7.2	4	7.6	10.3	12.3	12.75	
100	0.68	1.28	1.7	2.1	2.48	0.61	1.1	1.48	1.77	2	0.68	1.28	1.7	2.1	2.48	100-300
150	1.11	1.87	2.42	2.94	3.43	0.99	1.65	2.22	2.66	3	1.11	1.87	2.42	2.94	3.43	
200	1.49	1.96	3.1	3.58	3.6	1.22	2.2	2.96	3.54	4	1.4	2.45	3.24	3.83	4.3	
250	1.96	2.72	3.2	3.58	3.6	1.53	2.75	3.7	4.43	5	1.96	3.43	4.5	5.3	5.9	
300	2.55	3.54	3.56	3.58	3.6	1.83	3.3	4.44	5.31	6	2.55	4.5	5.3	5.9	6.35	
200	2	3.4	3.56	3.58	3.6	2.4	4.4	6	7.1	7.2	2.8	4.9	6.5	7.6	8.6	200-450 (Opt-80)
300	3	3.54	3.56	3.58	3.6	3.6	6.6	7.16	7.18	7.2	4.2	7.35	9.75	11.4	12.75	
400	3.52	3.54	3.56	3.58	3.6	4.8	7.14	7.16	7.18	7.2	5.6	9.8	12.7	12.73	12.75	
450	3.52	3.54	3.56	3.58	3.6	5.4	7.14	7.16	7.18	7.2	6.3	11	12.7	12.73	12.75	

**TABLE 3B
FULL PORT FLOW CAPACITY – Cv
COMPOSITION DIAPHRAGM $F_L = 0.90$**

Pressure Setpoint Psp psig	Cv Capacity @ % Build										Range Spring psig
	BODY SIZE – 1-1/4" (DN32)					BODY SIZE – 1-1/2" (DN40)					
	10%	20%	30%	40%	50%	10%	20%	30%	40%	50%	
1	1.78	2.91	3.83	4.69	5.5	1.87	3.23	4.51	5.7	6.83	1-5
3	4.04	6.89	9.61	12.2	14.6	4.25	7.65	11.3	14.7	18	
5	6.62	11.5	16	20	20.7	6.97	12.2	18	23.5	25.5	
1	0.86	1.42	1.85	2.26	2.64	0.88	1.55	2.18	2.78	3.35	1-10
5	3.91	6.67	9.27	11.7	14	4.12	7.4	11	14.3	17.5	
10	6.16	13.3	18.5	20	20.7	6.72	14	19	24	25.5	
5	2.26	4.05	5.59	7.04	8.4	2.38	4.51	6.59	8.55	10.4	5-20
10	4.85	8.67	11.5	14.1	16.6	5.1	9.69	13.5	17.1	20.5	
15	7.3	13	17	19.6	20.7	8	16.8	22.8	25	25.5	
20	9.7	17.3	20	20.3	20.7	10	18	24.5	25	25.5	15-45
15	3.79	6.89	9.1	11.2	13.1	4	7.65	10.7	13.6	16.3	
25	6.3	11.1	14.9	18.4	19.6	6.63	12.4	17.5	22.3	25.5	
35	8.76	15.2	19.6	19.6	0	9.27	16.9	23.4	25	25.5	10-70
45	11.4	19.8	20	20.3	20.7	12.8	21	24.5	25	25.5	
10	1.33	1.91	3.18	4.37	5.49	1.4	2.13	3.74	5.26	6.69	
30	3.63	6.35	8.67	10.9	12.9	3.83	7.06	10.2	13.2	15.9	40-125
50	6.26	10.7	14	17.1	19.6	6.59	12	16.6	20.9	24.9	
70	8.5	14.8	20	20.3	20.7	9	15	23	25	25.5	
40	2.18	4.36	5.99	7.53	8.97	2.3	4.85	7.06	9.13	11.1	70-200
50	3.23	5.66	7.58	9.39	11.1	3.4	6.29	8.93	11.4	13.7	
75	4.44	7.73	10.5	13	15.4	4.68	8.59	12.3	15.8	19.1	
100	5.85	9.95	13.1	16	18.8	6.16	11.1	15.5	19.5	23.4	100-400 (Opt-80)
125	7.27	12.4	16.4	20	20.7	7.65	13.9	19.3	24.4	25.5	
70	2.42	4.85	6.86	8.75	10.5	2.55	5.4	8.08	10.6	13	
100	3.95	5.66	8.5	11.2	13.7	4.17	6.29	10	13.5	16.9	100-400 (Opt-80)
125	4.56	8.42	11.7	14.8	17.8	4.8	9.35	13.9	18.1	22.1	
150	5.33	9.27	14.5	19.3	20.7	5.61	10.4	17.1	23.4	25.5	
175	6.05	11.3	14.9	19.6	20.7	6.38	12.6	18	25	25.5	100-400 (Opt-80)
200	7.43	11.8	17	20.3	20.7	7.82	13	18.8	25	25.5	
100	5.1	7.4	11	14.5	17.8	5.5	8	11.5	14.8	18.2	
200	9.6	14.7	20	20.3	20.7	10	15	22	25	25.5	100-400 (Opt-80)
300	14.4	20	20.2	20.4	20.7	15	22	25	25.3	25.5	
400	19	20	20.2	20.4	20.7	19.5	24.5	25	25.3	25.5	

**TABLE 3C
FULL PORT FLOW CAPACITY – Cv
COMPOSITION DIAPHRAGM $F_L = 0.90$**

Pressure Setpoint Psp psig	Cv Capacity & % Build					Range Spring psig
	BODY SIZE – 2" (DN50)					
	10%	20%	30%	40%	50%	
1	4.25	10.6	14.9	18.9	22.6	1-5
3	14.5	27.6	40.3	50	51	
5	23.4	45	49	50	51	
1	2.02	5.2	7.27	9.21	11	1-10
5	13.9	25.7	38.3	50	51	
10	22.1	41	49	50	51	
5	7.23	12.8	18.3	23.5	28.4	5-15
10	12.3	24.7	37	48.6	51	
15	19	36	49	50	51	
10	4.17	8.5	12.8	16.7	20.5	10-30
20	10	17	27.7	37.8	47.2	
30	15	25	38	50	51	
15	2.55	5.95	9.35	12.5	15.6	15-50
25	5.1	9.78	14.6	19.2	23.5	
35	7.4	15.1	22.5	29.5	36	
50	10.6	19	29	38	47	30-90
30	3.4	5.87	8.93	11.8	14.5	
60	6.97	12.8	18.7	24.3	29.6	
90	10.2	19	28	36	44	50-150
50	3.19	6.8	10.2	13.4	16.4	
75	5.1	11.8	15.2	18.4	21.4	
100	6.97	13.9	20.4	26.6	32.3	80-300 (Opt-80)
125	8.08	17	25.5	33.5	41	
150	10.6	21	30	40	48	
80	7	14	20	24	28	80-300 (Opt-80)
100	9	18	26	34	42	
200	18	36	49	50	51	
300	25	48	49	50	51	

TABLE 3D
FULL PORT FLOW CAPACITY – Cv
COMPOSITION DIAPHRAGM $F_L = 0.90$

Pressure Setpoint Psp psig	Cv Capacity @ % Build															Range Spring psig
	BODY SIZE – 2-1/2" (DN65)					BODY SIZE – 3" (DN80)					BODY SIZE – 4" (DN100)					
	10%	20%	30%	40%	50%	10%	20%	30%	40%	50%	10%	20%	30%	40%	50%	
1	4.12	6.33	8.46	10.5	12.3	5.95	11.1	17	22.6	27.9	12.8	20	27	33	38	1-10
3	8.46	16	24.9	33.3	41.2	12.8	24.2	34	43.2	52	17	34	51	67	82	
5	18	35.3	52	68	76.5	24.7	45.1	63	80	95	29.8	60	89	117	144	
10	31.9	60	75	76	76.5	53	90	102	105	108	64	110	150	185	187	
5	14.9	24.7	34	42.8	51	11.5	20.7	29.8	38.3	46.3	25.5	42.5	61	79	95	5-20
10	25.5	41.7	53	63	73	23	41.7	58	73	87	40.8	78	102	124	145	
15	36.1	57	71	76	76.5	38.3	65	87	102	108	64	106	136	164	187	
20	48.5	70	74	76	76.5	55	92	102	105	108	85	150	180	184	187	
10	14.9	27.6	40.4	52	64	11.9	21.3	30.3	38.9	46.9	21.3	40.8	57	72	86	10-40
20	26.4	46.8	60	73	76.5	29.4	51	68	84	99	43.4	86	116	114	170	
30	36.8	61	74	76	76.5	44.2	74	96	102	108	60	108	145	179	187	
40	51	72	74	76	76.5	57	94	102	105	108	89	150	180	184	187	
10	5.1	9.35	15	20.2	25.2	4.25	9.78	15.3	20.5	25.4	6.8	14.5	22	29	36	10-70
30	14.9	27.9	40	51	62	12.8	23.4	35.7	47.3	58	23.4	45.1	66	86	105	
50	24.5	44.2	60	76	76.5	23.8	45.1	61	76	91	41.2	80	112	143	171	
70	34	64	74	76	76.5	41.9	80	102	105	108	57	105	142	170	187	
40	6.38	15.7	23	29.7	36.1	10.2	20.4	29.8	38.5	46.8	21.3	36.1	48	60	71	40-125
50	10.6	21.3	31.5	41	50	14.5	27.6	39.1	49.9	60	25.1	40.8	57	72	86	
75	17	32.3	44.2	55	66	23.4	42.5	60	77	93	34	57	78	98	117	
100	22.4	42.5	58	72	76.5	30.6	55	77	96	108	40.8	71	97	122	145	
125	29.8	57	71	76	76.5	36.1	57	70	90	108	48.5	90	126	158	186	
50	8.29	17	25.2	32.8	40	11.6	22.1	31.3	39.9	48	20.1	32.6	46	58	70	50-225
100	18.7	35.3	47.6	59	70	25.3	45.9	64	81	96	33.8	59	81	102	121	
150	29.8	56	74	76	76.5	40.6	73	99	105	108	53	94	129	163	187	
225	39.6	64	74	76	76.5	48.5	88	102	105	108	65	110	150	182	187	

TABLE 4A
FULL PORT FLOW CAPACITY – Cv
METAL DIAPHRAGM
 $F_L = 0.90$

Pressure Setpoint Psp psig	Cv Capacity @ % Build									Range Spring psig
	BODY SIZE – 1/2" DN(15)			BODY SIZE – 3/4" (DN20)			BODY SIZE – 1" (DN25)			
	2.5%	5.0%	10.0%	2.5%	5.0%	10.0%	2.5%	5.0%	10.0%	
5	0.3	0.6	1.19	0.3	0.6	1.23	0.34	0.64	1.28	5–20
10	0.6	1.23	2.47	0.6	1.23	2.51	0.64	1.28	2.55	
15	1.15	2.21	2.6	1.15	2.21	2.6	1.19	2.25	3	
20	1.53	2.6	0	1.53	2.55	0	1.57	2.98	0	
10	0.21	0.38	0.94	0.21	0.38	0.98	0.26	0.43	1.02	10–35
20	0.55	1.02	2.13	0.55	1.02	2.17	0.6	1.06	2.21	
30	0.98	1.87	0	0.98	1.87	0	1.02	1.91	0	
35	1.11	0	0	1.11	0	0	1.15	0	0	20–80
20	0.13	0.3	0.6	0.13	0.3	0.64	0.17	0.34	0.68	
40	0.38	0.77	1.53	0.38	0.77	1.57	0.43	0.81	1.62	
60	0.64	1.4	2.6	0.64	1.4	2.6	0.68	1.45	2.89	
80	1.06	0	0	1.06	0	0	1.11	0	0	30–150
30	0.13	0.3	0.55	0.13	0.3	0.6	0.17	0.34	0.64	
50	0.26	0.55	1.06	0.26	0.55	1.11	0.3	0.6	1.15	
75	0.47	0.98	1.83	0.47	0.98	1.87	0.51	1.02	1.91	
100	0.6	1.19	2.38	0.6	1.19	2.47	0.6	1.23	2.55	
125	0.98	1.91	2.6	0.98	1.91	2.6	1.02	1.96	3	
150	1.15	0	0	1.15	0	0	1.19	0	0	70–200
70	0.13	0.21	0.43	0.13	0.21	0.43	0.13	0.21	0.43	
100	0.34	0.77	1.53	0.34	0.77	1.57	0.38	0.81	1.62	
125	0.55	1.11	2.13	0.55	1.11	2.17	0.6	1.15	2.25	
150	0.68	1.4	2.42	0.68	1.4	2.47	0.72	1.4	2.72	
175	0.77	1.53	2.6	0.77	1.53	2.6	0.81	1.57	3	
200	0.98	0	0	0.98	0	0	1.02	0	0	100–300
100	0.21	0.43	0.81	0.21	0.43	0.81	0.21	0.43	0.81	
150	0.38	0.68	1.28	0.38	0.68	1.32	0.43	0.72	1.36	
200	0.47	0.89	1.57	0.47	0.89	1.62	0.51	0.94	1.7	
250	0.64	1.15	2	0.64	1.15	2.08	0.68	1.19	2.17	
300	0.72	0	0	0.72	0	0	0.77	0	0	
200	0.81	1.87	2.6	0.81	1.87	2.6	0.85	1.91	3	200–450 (Opt-80)
300	1.45	2.6	0	1.45	2.55	0	1.49	2.98	0	
400	2.25	2.6	0	2.3	2.55	0	2.34	2.98	0	
450	2.6	0	0	2.6	0	0	3	0	0	

TABLE 4B
FULL PORT FLOW CAPACITY – Cv
METAL DIAPHRAGM
 $F_L = 0.90$

Pressure Setpoint Psp psig	Cv Capacity @ % Build						Range Spring psig
	BODY SIZE – 1-1/4" (DN32)			BODY SIZE – 1-1/2" (DN40)			
	2.5%	5.0%	10.0%	2.5%	5.0%	10.0%	
5	0.55	1.02	2.04	0.6	1.06	2.13	5–20
10	1.23	2.47	4.34	1.28	2.55	4.51	
15	2.34	4.68	5.1	2.38	4.76	5.1	
20	3.91	0	0	4	0	0	
15	0.81	1.62	3.02	0.85	1.7	3.19	15–45
25	1.4	2.72	4.97	1.45	2.89	5.1	
35	1.91	3.74	5.1	1.96	3.91	5.1	
45	2.89	0	0	2.98	0	0	10–70
10	0.3	0.6	1.11	0.3	0.6	1.15	
30	0.81	1.57	3.02	0.85	1.66	3.19	
50	1.62	3.15	5.1	1.66	3.27	5.1	
70	2.3	0	0	2.38	0	0	40–125
40	0.55	1.06	2.04	0.55	1.11	2.21	
50	0.72	1.4	2.59	0.72	1.45	2.76	
75	1.06	2.13	4.08	1.11	2.21	4.25	
100	1.4	2.85	4.93	1.49	2.98	5.1	
125	1.83	0	0	1.91	0	0	70–200
70	0.55	1.06	1.96	0.55	1.11	2.13	
100	0.94	1.7	3.23	0.94	1.79	3.4	
125	1.06	2	3.78	1.11	2.08	3.95	
150	1.19	2.25	4.38	1.23	2.38	4.59	
175	1.4	2.72	4.97	1.49	2.85	5.1	
200	1.79	0	0	1.87	0	0	100–400 (Opt-80)
100	0.55	0.98	1.66	0.55	1.02	1.7	
200	1.06	2	3.78	1.11	2.08	3.95	
300	1.45	2.81	4.97	1.53	2.89	5.1	
400	2.13	0	0	2.21	0	0	

TABLE 4C
FULL PORT FLOW CAPACITY – Cv
METAL DIAPHRAGM
 $F_L = 0.90$

Pressure Setpoint Psp psig	Cv Capacity @ % Build			Range Spring psig
	BODY SIZE – 2" (DN50)			
	2.5%	5.0%	10.0%	
5	2.13	4.25	6.38	5–15
10	3.83	7.65	10.2	
15	4.25	0	0	
10	0.94	1.79	3.4	10–30
20	2.13	4.25	8.5	
30	3.91	0	0	
15	0.55	1.06	2.13	15–50
25	1.06	2.13	4.25	
35	1.62	3.19	6.38	
50	2.55	0	0	30–90
30	0.72	1.4	2.64	
60	1.45	2.76	5.53	
90	2.13	0	0	50–150
50	0.68	1.32	2.64	
75	1.06	2.13	4.25	
100	1.49	2.98	5.95	
125	1.91	3.83	7.52	
150	2.47	0	0	
80	0.49	0.96	1.91	80–300 (Opt-80)
100	0.64	1.28	2.55	
200	1.49	2.85	5.65	
300	2.13	0	0	

DAG TECHNICAL APPENDIX INDEX

<u>TABLE</u>	<u>TITLE</u>	<u>PAGE</u>
DAG-1A	DI – Press vs Temp vs End Conn Ratings	11
DAG-1B	BRZ – Press vs Temp vs End Conn Ratings	12
DAG-1D	CS – Design Inlet/Outlet - DA5	13
DAG-1F.....	SST – Design Inlet/Outlet - DA5.....	13
DAG-1H.....	HC – Design Inlet/Outlet - DA5.....	14
DAG-2.....	Max Pressure Drop - Comp Seat	15
DAG-3.....	Max Pressure Drop - Dynamic Seal Design.....	15
DAG-4.....	Max Pressure Drop - Basic Trim Mat'ls.....	15
DAG-5.....	Temperature Limits – Elastomer Mat'ls.....	16
DAG-7.....	Back Pressure Max Capacity - Plug Wide Open.....	17
DAG-10.....	Inboard Leakage Ratings	17
DAG-12.....	Back Press Recommended Velocity Limits.....	17
DAG-14.....	Recommended Internal Materials - Liquids.....	18
DAG-14.....	Recommended Internal Materials - Gases.....	18
DAG-14.....	Supplement - Chemical Resistance	19

<u>FIGURE</u>	<u>TITLE</u>	<u>PAGE</u>
DAG-F1.....	Dynamic/Static Seals	20
DAG-F2.....	Location of Body/Spring Chamber Taps	21

**TABLE DAG-1A
DI – DUCTILE IRON
BODY / TOPWORKS MATERIAL SPECIFICATIONS**

**DESIGN PRESSURE vs. TEMPERATURE vs. END CONNECTION RATINGS
(To ASME B16.1 for Flanged and B16.4 for NPT Connections per Cast Iron Rating)**

Material Specifications (Body / Topworks)		End Connection – Inlet & Outlet					
		Temperature °F	Working Pressure – psig				
Description (Abbr.)	ASTM No.		End Connection – Pressure Class				
			NPT	125# FF	250# RF		
DI/DI (Note 1)	A395/ A395	-20° to +150°	400	200	500		
		200°	370	190	460		
		225°	355	180	440		
		250°	340	175	415		
		300°	310	165	375		
		350°	300	150	335		
		400°	250	140	290		
		406°	250	140	290		
			400 WOG, 250 S	225 WOG, 125 S	400 WOG, 250 S		
				Working Pressure – Barg			
				End Connection – Pressure Class			
				NPT	125# FF	250# RF	
				-29° to +65°	27.6	13.8	34 .5
				107	24.5	12.5	30.2
				120°	23.4	12.1	28.7
				150°	21.2	11.2	25.7
		177°	19.2	10.6	23.8		
		204°	17.5	9.6	20.3		

NOTE 1: Whenever body and topworks materials are mixed, the P vs. T ratings that should be applied are those which are lowest of the two materials.

Example: CS body, DI topworks; NPT end connections, 200°F temperature.

Because the topworks is not “end flanged”, use the DI limits of “400 PSIG CWP 370/200F” from above to compare to CS limits from DAG-1C values. The DI limits are lower, so ratings from DAG-1A MUST be used as the limits.

NOTE 2: Unless stated otherwise, design pressure is Maximum Allowable Working Pressure (MAWP) for Inlet and Outlet.

**TABLE DAG-1B
BRZ – BRONZE
BODY / TOPWORKS MATERIAL SPECIFICATIONS**

**DESIGN PRESSURE vs. TEMPERATURE vs. END CONNECTION RATINGS
(Per ASME B16.24 for Flanged and B16.15 for NPT Connections)**

Material Specifications (Body / Topworks)		End Connection – Inlet & Outlet (Note 2)				
Description (Abbr.)	ASTM No.	Temperature °F	Working Pressure – psig			
			End Connection – Pressure Class			
			NPT	150# FF	300# FF	
BRZ/BRZ (Note 1)	B62, Alloy C83600/B62, Alloy C83600	-325° to +150° *	500	225	500	
		175°	390	220	480	
		200°	385	210	465	
		225°	375	205	445	
		250°	365	195	425	
		300°	335	180	390	
		350°	300	165	350	
		400°	250	150	315	
		406°	250	150	315	
		Temperature °C	Working Pressure – Barg			
			End Connection – Pressure Class			
			NPT	150# FF	300# FF	
			-198° to +65° *	34.5	15.5	34.5
			107°	25.8	14.0	30.8
			120°	25.1	13.5	29.5
			150°	23.0	12.4	26.8
			177°	20.4	11.3	24.0
204°	17.8	10.3	21.4			

NOTE 1: Whenever body and topworks materials are mixed, the P vs. T ratings that should be applied are those which are lowest of the two materials.

Example: BRZ body, DI topworks; NPT end connections, ambient temperature.
Because the topworks is not “end flanged”, use the DI limits of "400 PSIG CWP 370/200F" from DAG-1A to compare to above DAG-1B values. The DI limits are lower, so ratings from DAG-1A MUST be used as the limits.

NOTE 2: Unless stated otherwise, design pressure is Maximum Allowable Working Pressure (MAWP) for Inlet and Outlet.

* See Minimum Temperature Ratings Table below.

**DESIGN PRESSURE RATING
AT MIN. TEMPERATURE**

Regulator Function	Material Specifications (Body / Topworks - Connections) Description (Abbr.)	Pressure at Min. Temperature
Back Pressure Relief	BRZ/BRZ	Inlet - 500 psig CWP to -325°F (-198°C)
		Outlet - 500 psig CWP to -325°F (-198°C)
	SST/SST - NPT, BSP, Ext. Nipples, Tube Ends and 600# Flgs	Inlet - 625 psig CWP to -425°F (-254°C)
		Outlet - 625 psig CWP to -425°F (-254°C)

Body Material Specifications

Cast Steel A216 Gr.WCB or Steel Weldment A216 Gr. WCB w/ forged flanges A105

Alternate Material: Cast Steel A352 Gr. LCC or Steel Weldment A352 Gr. LCC w/ forged flanges A350 Gr. LF6 Class 2

Topworks Material Specifications

Cast Steel A216 Gr. WCB.

(For Option-80 Sizes 1/2"-1-1/2" Steel Weldment A516 Gr. 55 & A106; Size 2" ASTM A216, Gr. WCB)

Alternate Material: Cast Steel A352 Gr. LCC

DESIGN PRESSURE vs. TEMPERATURE vs. END CONNECTION RATINGS

(Per ASME B16.5 and B16.34) See NOTE 1

TABLE DAG-1D DESIGN PRESSURE (BOTH INLET AND OUTLET) FOR DA5 in PSIG (BARG)			
CONSTRUCTION	END CONNECTIONS		
DESIGN TEMP. RANGE: Deg F (Deg C) **	NPT, BSP, 600#, EXTD NIPP	150#	300#
-20 to +100 (-29 to +38)	750 (51.7)	285 (19.6)	740 (51.1)
-20 to +200 (-29 to +93)	680 (47.1)	260 (17.9)	680 (47.1)
-20 to +300 (-29 to +149)	655 (45.1)	230 (15.8)	655 (45.1)
-20 to +400 (-29 to +204)	635 (43.6)	200 (13.7)	635 (43.8)

** Alternate Mat'l: ASTM 352 Gr. LCC Min. Temperature -50 °F(-46°C).

Body Material Specifications

Cast Stainless Steel A351 Gr.CF3M or Stainless Steel Weldment A315 Gr. CF3M w/ forged flanges A182 Gr. F 316L

Alternate Material: Super Duplex SST A995/A995M Gr. 6A

Topworks Material Specifications

Cast Stainless Steel A351 Gr.CF3M.

(For Option-80 Sizes 1/2"-1-1/2" Stainless Steel Weldment A312 Gr. 316/316L, A479 Gr. 316/316L, Size 2" is ASTM A351 Gr. CF3M)

Alternate Material: Super Duplex SST A995/A995M Gr. 6A

DESIGN PRESSURE vs. TEMPERATURE vs. END CONNECTION RATINGS

(Per ASME B16.5 and B16.34) See NOTE 1 using SST conditions; & NOTE 2

TABLE DAG-1F DESIGN PRESSURE (BOTH INLET AND OUTLET) FOR DA5 in PSIG(BARG)			
CONSTRUCTION	END CONNECTIONS		
DESIGN TEMP. RANGE: Deg F (Deg C)	NPT, BSP, 600#, EXTD NIPP, TUBE	150#	300#
-425 to +100 (-254 to +38)	625 (43.0)	275 (19.0)	625 (43.0)
-20 to +200 (-29 to +93)	620 (42.3)	235 (16.5)	620 (42.3)
-20 to +300 (-29 to +149)	560 (38.6)	215 (14.8)	560 (38.6)
-20 to +400 (-29 to +204)	515 (35.5)	195 (13.6)	515 (35.5)

NOTE 1: These pressure ratings may be further derated by limitations thru the Pressure Equipment Directive (97/23/EC-May '97). Whenever body and topworks are mixed, the P vs. T ratings that should be applied are those which are lowest for the two materials. **Example:** 600 lb. RF flanged **steel** body at 200 deg F maximum temp would have a preliminary inlet to 680 psig, but if fitted with a **ductile iron** topworks pressure rating is only 370 psig. Must derate both the inlet and outlet to 370 psig. (Note: Topworks pressure rating, same as NPT design outlet pressure rating for the selected topworks material and diaphragm type.)

NOTE 2: Maximum Design Pressure Rating for 2" Opt -41 limited by 0.065" wall thickness to 1200 psig.

300# Flanges are derated due to the bolting for these products.

Body Material Specifications

Cast Hastelloy A494 Gr.CW-12MW or Hastelloy Weldment A494 Gr. CW-12MW w/ forged flanges B462 Gr. N10276

Topworks Material Specifications

Cast Steel A216 Gr. WCB. (For Option-80 Steel Weldment A516 Gr. 55 & A106)

DESIGN PRESSURE vs. TEMPERATURE vs END CONNECTION RATINGS
(Per ASME B16.5 and B16.34) See NOTE 1

TABLE DAG-1H			
DESIGN PRESSURE (BOTH INLET AND OUTLET)			
FOR DA5 in PSIG (BARG)			
CONSTRUCTION	END CONNECTIONS		
DESIGN TEMP. RANGE: Deg F (Deg C)	NPT, BSP	150#	300#
-325 to +100 (-198 to +38)	625 (43.0)	230 (15.9)	600 (41.4)
-20 to +200 (-29 to +93)	550 (38.2)	210 (14.7)	550 (38.2)
-20 to +300 (-29 to +149)	520 (35.9)	200 (13.7)	520 (35.9)
-20 to +400 (-29 to +204)	490 (33.8)	190 (12.9)	490 (33.8)

NOTE 1: These pressure ratings may be further derated by limitations thru the Pressure Equipment Directive (97/23/EC-May '97).

**TABLE DAG-2
MAXIMUM PRESSURE DROP FOR
COMPOSITION SEATS**

Body Size		Max. Pressure Drop - psid (Bard)											
		Seat Material											
in	(DN)	POLYALL *, FKM						GF-TFE					
		Liquid *		Gas		Steam		Liquid *		Gas		Steam √	
1/2" – 1"	(15-25)	600	(41.3)	750	(51.7)	DNA		450	(31.0)	1000	(68.9)	150/125	(10.3/8.6)
1-1/4" – 1-1/2"	(32-40)	600	(41.3)	600	(41.3)	DNA		450	(31.0)	900	(62.0)	150/125	(10.3/8.6)
2"	(50)	600	(41.3)	600	(41.3)	DNA		450	(31.0)	750	(51.7)	150/125	(10.3/8.6)
2-1/2" – 4"	(65-100)	500	(34.4)	600	(41.3)	DNA		450	(31.0)	750	(51.7)	125	(8.6)
		V-TFE						CTFE					
1/2" – 1"	(15-25)	300	(20.7)	600	(41.3)	125	(8.6)	600	(41.3)	3000	(206.9)	DNA	
1-1/4" – 1-1/2"	(32-40)	300	(20.7)	600	(41.3)	125	(8.6)	600	(41.3)	3000	(206.9)	DNA	
2"	(50)	300	(20.7)	600	(41.3)	125	(8.6)	600	(41.3)	2000	(137.9)	DNA	
2-1/2" – 4"	(65-100)	300	(20.7)	450	(31.0)	125	(8.6)	500	(34.4)	1500	(103.4)	DNA	

* Only seat material to be applied in liquid "partially cavitating" service is PolyAll.
√ Steam Service: metal diaphragm/composition diaphragm.
N/A = Not Available
DNA = Do Not Apply

**TABLE DAG-3
MAXIMUM PRESSURE DROP FOR
DYNAMIC SEAL DESIGNS**

Body Size		Max. Pressure Drop - psid (Bard)																		
		Dynamic Seal Design																		
in	(DN)	"OR" – O-RING *						"CP" – TFE CAP						"CW" – TFE CAP w/WIPER						
		Liquid *		Gas *		Steam		Liquid		Gas		Steam		Liquid		Gas	Steam			
1/2" – 1"	(15-25)	600	(41.3)	750	(51.7)	DNA		600	(41.3)	600	(41.3)	DNA		450	(31.0)	600	(41.3)	DNA		
1-1/4" – 1-1/2"	(32-40)	600	(41.3)	750	(51.7)	DNA		600	(41.3)	600	(41.3)	DNA		450	(31.0)	600	(41.3)	DNA		
2"	(50)	600	(41.3)	750	(51.7)	DNA		600	(41.3)	600	(41.3)	DNA		450	(31.0)	600	(41.3)	DNA		
2-1/2" – 4"	(65-100)	600	(41.3)	750	(51.7)	DNA		600	(41.3)	600	(41.3)	DNA		450	(31.0)	600	(41.3)	DNA		
		"PR" – PISTON RING ASSY.						"PW" – PISTON RING ASSY. w/WIPER						"UC" – U-CUP						
1/2" – 1"	(15-25)	DNA		DNA		√	150/125	(10.3/8.6)	DNA		DNA		√	150/125	(10.3/8.6)	600	(41.3)	3000	(206.9)	DNA
1-1/4" – 1-1/2"	(32-40)	DNA		DNA		√	150/125	(10.3/8.6)	DNA		DNA		√	150/125	(10.3/8.6)	600	(41.3)	3000	(206.9)	DNA
2"	(50)	DNA		DNA		√	150/125	(10.3/8.6)	DNA		DNA		√	150/125	(10.3/8.6)	600	(41.3)	3000	(206.9)	DNA
2-1/2" – 4"	(65-100)	DNA		DNA		125	(8.6)	DNA		DNA		125	(8.6)	600	(41.3)	3000	(206.9)	DNA		

* Only seat material to be applied in liquid "partially cavitating" or "flashing" service is PolyAll.
√ Steam Service: metal diaphragm/composition diaphragm.
N/A = Not Available DNA = Do Not Apply wo/ = without w/ = with

**TABLE DAG-4
MAXIMUM PRESSURE DROP FOR
BASIC TRIM MATERIAL**

Body Size		Max Pressure Drop - psid (Bard)							
		Basic Trim Material							
in	(DN)	"P" – 17-4PH SST		"S" – 316L SST		"M" – Monel		"T" – Hybrid *	
1/2" – 2"	(15-50)	3000	(206.9)	800	(55.1)	1500	(103.4)	3000	(206.9)
2-1/2" – 4"	(65-100)	3000	(206.9)	800	(55.1)	1500	(103.4)	3000	(206.9)

* 17-4PH SST plug & piston, Monel cage.

**TABLE DAG-5
TEMPERATURE LIMITS
FOR ELASTOMERIC MATERIALS**

		Elastomer	T Maximum		T Minimum	
Seats	ID	Description	°F	(°C)	°F	(°C)
		PolyAll	Proprietary Polyurethane Derivative	225°	(107°)	-60°
	GF-TFE	Glass-filled Polytetrafluorethylene	425°	(218°)	-325°	(-198°)
	V-TFE	Virgin TFE	400°	(205°)	-325°	(-198°)
	CTFE	Chlorotrifluoroethylene TFE	300°	(148°)	-325°	(-198°)
	FKM	Fluorocarbon Elastomer	400°	(205°)	0°	(-17°)
Diaphragms	3-Ply	3-Ply TFE/FKM/TFE	400°	(205°)	0°	(-17°)
	BC	Neoprene (Polychloroprene)	250°	(121°)	-65°	(-53°)
	EPR	Ethylene Propylene	300°	(148°)	-40°	(-40°)
	FK	Fluorosilicone	350°	(177°)	-65°	(-54°)
	FKM	Fluorocarbon Elastomer	400°	(205°)	0°	(-17°)
	NBR	Buna-N (Nitrile)	250°	(121°)	-70°	(-56°)
	FKM+TFE	Fluorocarbon Elastomer + TFE	400°	(205°)	0°	(-17°)
Static Seals	RTFE	Bronze-filled TFE	425°	(218°)	70°	(21°)
	V-TFE	Virgin TFE	400°	(205°)	-325°	(-198°)
	EPR	Ethylene Propylene	300°	(148°)	-40°	(-40°)
	FK	Fluorosilicone	350°	(177°)	-65°	(-54°)
	FKM	Fluorocarbon Elastomer	400°	(205°)	-20°	(-28°)
	NBR	Buna-N	212°	(100°)	-40°	(-40°)
	SST/TFE	301/302 SST U-cup / TFE	400°	(205°)	-325°	(-198°)
	HC/TFE	Hastelloy C U-cup / TFE	400°	(205°)	-325°	(-198°)
Dynamic Seals	"PR"	Piston Ring Assy, GF-TFE / SST	425°	(218°)	-40°	(-40°)
	"PW"	PRA* w/Wiper, GF-TFE / SST / GF-TFE	425°	(218°)	70°	(21°)
	"CW" – EPR/TFE	TFE Cap Seal, EPR O-ring, GF-TFE Wiper	300°	(148°)	-40°	(-40°)
	"CW" – NBR/TFE	TFE Cap Seal, NBR O-ring, GF-TFE Wiper	212°	(100°)	-40°	(-40°)
	"CW" – FK/TFE	TFE Cap Seal, FK O-ring, GF-TFE Wiper	350°	(177°)	-40°	(-40°)
	"CW" – FKM/TFE	TFE Cap Seal, FKM O-ring, GF-TFE Wiper	400°	(205°)	-20°	(-28°)
	"CP" – EPR/TFE	TFE Cap Seal, EPR O-ring	300°	(148°)	-40°	(-40°)
	"CP" – NBR/TFE	TFE Cap Seal, NBR O-ring	212°	(100°)	-40°	(-40°)
	"CP" – FK/TFE	TFE Cap Seal, FK O-ring	350°	(177°)	-10°	(-23°)
	"CP" – FKM/TFE	TFE Cap Seal, FKM O-ring	400°	(205°)	-20°	(-28°)
	SST/TFE	301/302 SST U-cup / TFE	400°	(205°)	-325°	(-198°)
	HC/TFE	Hastelloy C U-cup / TFE	400°	(205°)	-325°	(-198°)
	ELG/TFE	Elgiloy / TFE U-cup	400°	(205°)	-325°	(-198°)

* PRA - Piston Ring Assembly

Metal Diaphragm		T Maximum		T Minimum	
ID	Description	°F	(°C)	°F	(°C)
BE-CU	Beryllium Copper	400°	(205°)	-325°	(-198°)

ABBREVIATIONS			
FK = Fluorosilicone	NBR = Buna-N	PTFE = Polytetrafluoroethylene	PRA = GF-TFE/SST
FKM = Fluorocarbon Elastomer	RTFE = Brz-fill TFE	V-TFE = Virgin TFE	BC = Neoprene
EPR = Ethylene Propylene	GF-TFE = Glass-fill TFE	CTFE = Chlorotrifluoroethylene TFE	ELG = Elgiloy

**TABLE DAG-7
BACK PRESSURE MAXIMUM CAPACITY WITH PLUG WIDE-OPEN**

Body Size		Full Port Max Capacity		Full Port Max Capacity	
in	(DN)	Cv	Kv	Cv	Kv
1/2"	(15)	4.0	3.4	3.0	2.6
3/4"	(20)	8.0	6.9	3.0	2.6
1"	(25)	12.8	11.0	3.0	2.6
1-1/4"	(32)	23	20	5.1	4.4
1-1/2"	(40)	26	22	5.1	4.4
2"	(50)	51	44	10.2	8.8
2-1/2"	(65)	77	66	X	
3"	(80)	120	104		
4"	(100)	187	161		
Diaphragm		Composition		Metal	

NOTE: The above Cv factors may be used for sizing of safety relief valves or rupture discs.

**TABLE DAG-10
INBOARD LEAKAGE RATINGS *
Per ANSI/FCI 70-2**

Seat Material	Dynamic Seal	
	O-Ring	Dynamic Seals Except O-Ring
CTFE, GF-TFE, and V-TFE	IV	IV
PolyAll, FKM	VI	IV

*Inboard leak rates are the composite leakage of the seat leakage + dynamic seal leakage, considered as a single inboard leakage value.

**TABLE DAG-12
BACK PRESSURE RECOMMENDED VELOCITY LIMITS**

Application Fluid	Valve			Upstream Pipe		Valve Body		Downstream Pipe	Units	
	Type	Size Range				Inlet (1-Phase)				Outlet
		in	(DN)	Recommend	Max.	Recommend	Max.			
Liquid	BPV	1/2"-4"	(15-100)	5-8	16	15	20	See Notes 1 & 2 Below	See Notes 3 & 4 Below	Ft/Sec
		6"	(150)	7-12	20	15	24			
	X	8"-12"	(200-300)	9-14	24	-	-			
Gas	BPV	1/2"-1"	(15-25)	0.15	0.30	0.15	0.25	<1.00	<0.8	Mach #
		1-1/4"-2"	(32-50)	0.20	0.30	0.20	0.30			
	X	2-1/2"-6"	(65-150)	0.22	0.30	0.25	0.35			
Steam	BPV	1/2"-1"	(15-25)	0.10	0.30	0.20	0.30	<0.8	<0.65	Mach #
		1-1/4"-2"	(32-50)	0.12		0.22				
	X	2-1/2"-6"	(65-150)	0.15		0.25				
X	8"-12"	(200-300)	0.20		-	-				

- NOTES:**
- Liquids experiencing no 2-phase flow at valve outlet will have same valve body outlet velocity as inlet velocity.
 - Liquids experiencing 2-phase flow at valve outlet should have average velocity less than 150-200 ft/sec.
 - Liquids experiencing 2-phase flow at outlet pipe should have average velocity less than 20-50 ft/sec.
 - If valve outlet exceeds recommended limits, then can use external sensing to reach maximum limits.
 - On gas service, a pilot operated prv can work with a outlet Mach = 0.75.

TABLE DAG-14
RECOMMENDED INTERNAL MATERIALS
For P_{max}' Reference Individual Technical Bulletins

LIQUIDS				
LIQUIDS	Fluid	Tmax °F	Tmin °F	Metal Trim
	LIQUIDS	Industrial Water – Cold	180°	32°
Hot		225°	32°	PJ
DI, DM		225°	32°	PJ
		250°	32°	PL
Seawater		180°	-20°	MQ
Fuel Oils – Diesel, #1,#2‡		180°	-40°	P6
Bunker C, #3 - #6‡		180°	-40°	P6
		400°	0°	PD
Jet Fuel JP3, JP4, JP5, JP6‡		400°	0°	PD
Kerosene‡		400°	0°	PD
Crude Oils – Sweet‡		225°	0°	PB
		400°	0°	PD
Sour‡		225°	0°	NS
Heat Transfer Oils – Dowtherm, Therminol, Mobil-Therm, Silvatherm		400°	0°	PD
Misc. Oils – Lube Oil‡		180°	-40°	P6
Naptha‡	400°	0°	PD	
Turbine Oil‡	225°	0°	PB	
LIQUIDS	Edible Oils – Vegetable Oil‡	180°	-30°	PH
	Animal Fats‡	180°	-30°	PH
	Seed Oils‡	180°	-30°	PH
	Inorganic Acids – Acetic - 5%	100°	0°	CF *
	Acetic - 30%	100°	0°	CF *
	Sulfuric - conc.	100°	0°	CF *
	Sulfuric - dilute	100°	0°	CF *
	Nitric - conc.	140°	0°	CF *
	Nitric - dilute	140°	0°	CF *
	Hydrofluoric (air free) - dilute, concentrate	100°	0°	CF *
	Hydrobromic	140°	0°	CF *
	Phosphoric - dilute, concentrate	150°	0°	CF *
	Misc. Liquids – Gasoline‡	150°	-40°	P6
	Benzene (C ₆ H ₆)‡	150°	0°	CF *
	Chlorine (Cl ₂)	150°	0°	ML
Bromine (Br ₂)	150°	0°	CF *	
Ammonia (NH ₃)	140°	0°	CF *	
Hydrogen Peroxide (H ₂ O ₂)	125°	0°	CF *	
Hydrogen Chloride (HCl)	125°	0°	ML	
Hydrogen Bromide (HBr)	125°	0°	SL	
Cane Sugar Liquor	180°	0°	PH	

‡ In accordance with ASME B31.3 "Process Piping", do not use Ductile Iron Body for hydrocarbon or flammable service with inlet pressures greater than 150 psig (10.3 Barg) or temperatures greater than 300 deg F (149 deg C).
 * CF = Consult Factory

GASES				
GASES	Fluid	Tmax °F	Tmin °F	Trim
	Atmospheric Gases	Atmospheric Gases – O₂ (GOX)	225°	-60°
350°			-65°	M9
350°			-325°	TN
N ₂ (GN ₂), Air, Argon		180°	-60°	P2
		350°	-65°	P8
CO ₂ (dry)		180°	-40°	P6
CO ₂ (wet)	180°	-40°	P6	
Process Gases	Process Gases – Nat. Gas (Sweet)	180°	-65°	P9
	Nat. Gas (Sour)	180°	-40°	NR
	LPG (propane)	180°	-40°	PH
	Ammonia	120°	-40°	CF *
	Hydrogen	180°	-325°	SN
	Helium	180°	-325°	SN
	Chlorine (dry)	200°	0°	ME
	Hydrogen Chloride (dry)	120°	-40°	CF *
	Hydrogen Bromide (dry)	120°	0°	PE
	Hydrogen Fluoride (dry)	120°	0°	PE
	Hydrogen Sulfide (dry)	140°	0°	NS
	Hydrogen Sulfide (wet)	140°	0°	NS
	Sulfur Dioxide (dry)	120°	0°	PE
STEAM	P1 ≤ 125 psig	350°	—	PG

DAG-14 SUPPLEMENT CHEMICAL RESISTANCE

General Statement: Statements located within this technical bulletin concerning suitability of fluids with TFE materials are general statements, and should not be construed as recommendations. Any statements of suitability are the result of a compilation of various sources of information based on experience, tests, and published technical literature. No guarantee or warranty is in anyway implied for a given particular service or application.

Additional Reference: For an inclusive listing covering a broader range of service application fluids, reference "Handbook of Corrosion Resistant Piping", P.A. Schweitzer, Industrial Press or "Compass Corrosion Guide", 2nd Edition, K.M. Pruett, Compass Publications. This publication will include information based on the following fluid variables:

1. Solution concentration
2. Pressure
3. Temperature

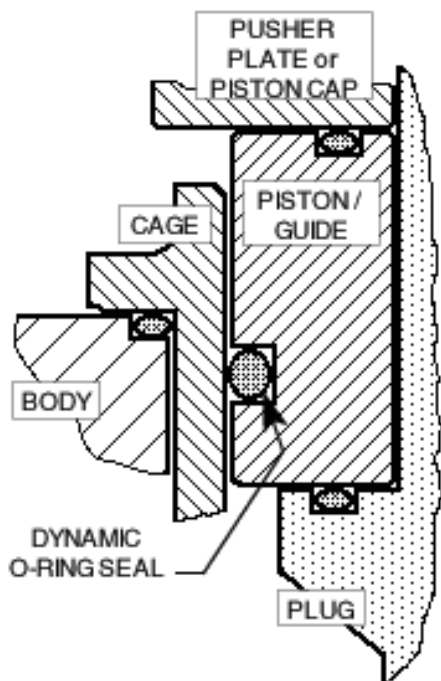

O-RING DYNAMIC SEAL

PRV, BPV

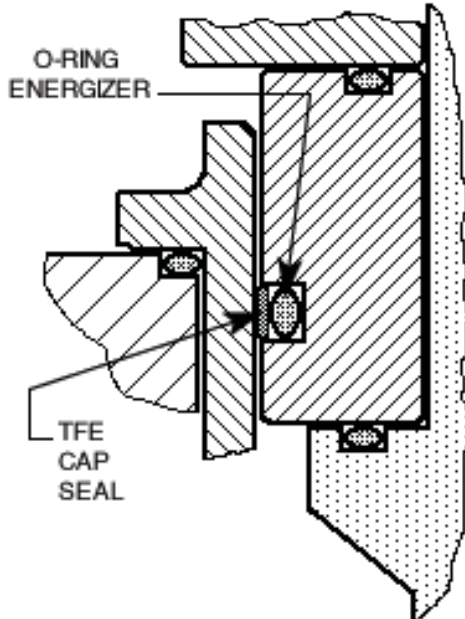

TFE CAP DYNAMIC SEAL

BPV

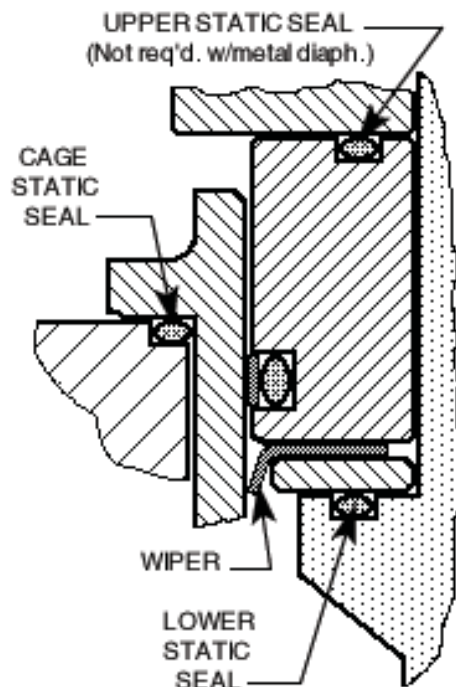

TFE CAP DYNAMIC SEAL + WIPER

PRV

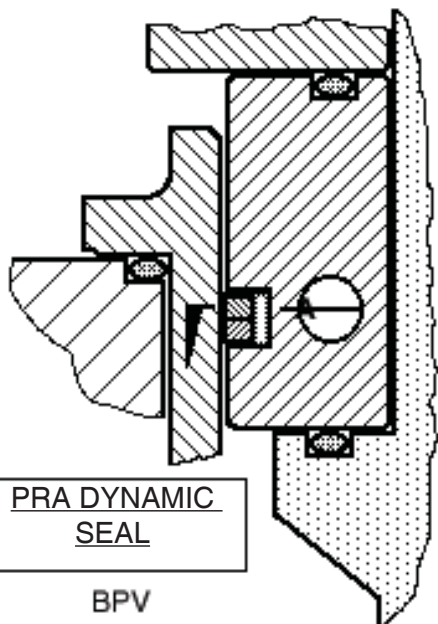

PRA DYNAMIC SEAL

BPV

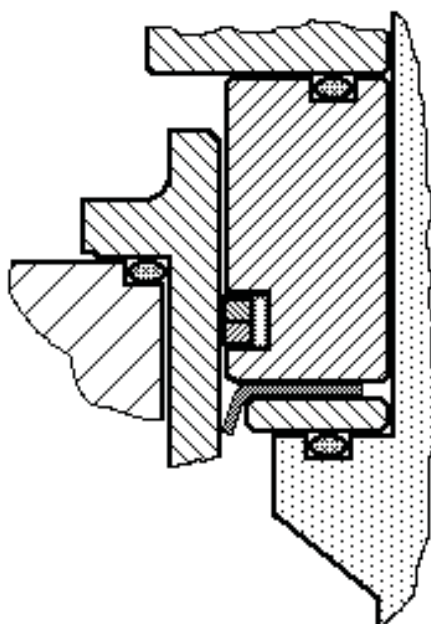

PRA DYNAMIC SEAL + WIPER

PRV

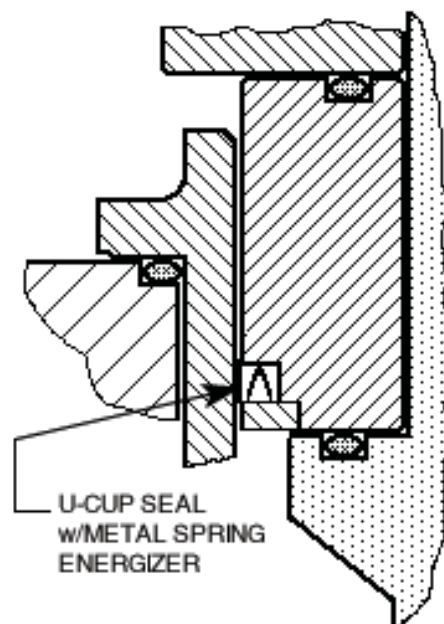

U-CUP DYNAMIC SEAL

PRV, BPV

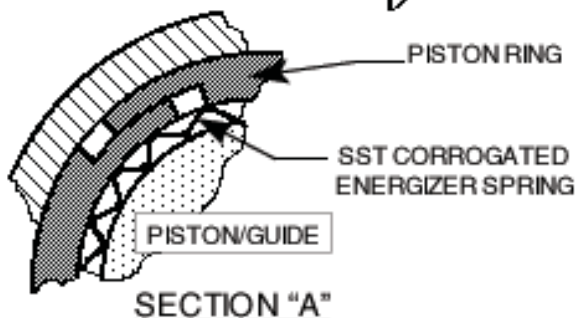

SECTION "A"

FIGURE DAG-F1
DYNAMIC & STATIC SEALS

FIGURE DAG-F2
Location of BODY / SPRING CHAMBER TAPS

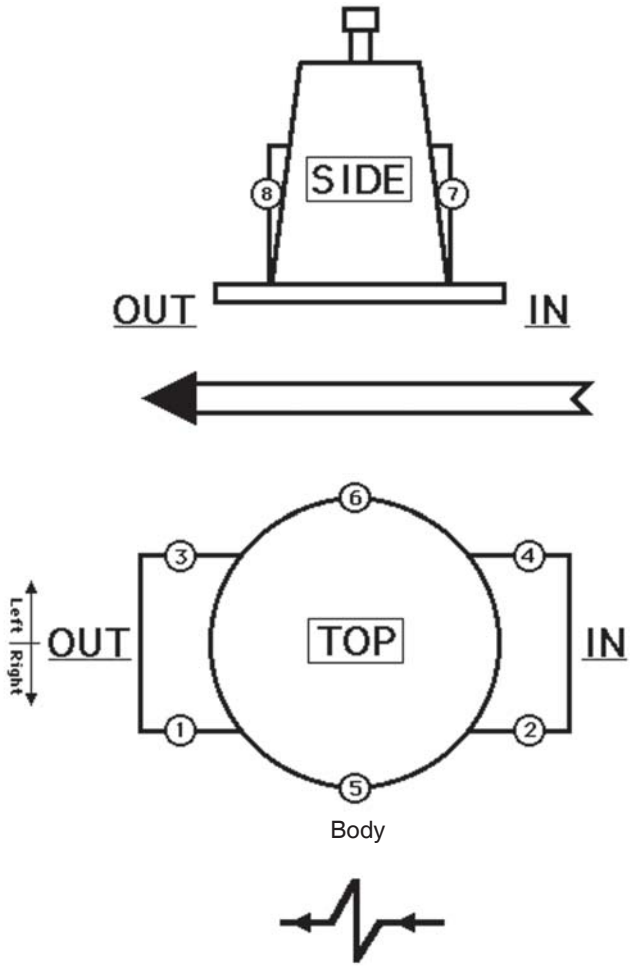

Flow To Open Direction

Location	Description	Opt. No.	NPT - Size	Body Mat'l.
1 & 2	Inlet & Outlet – Right	STD	1/4"	DI, CS, & SST
1, 2 & 3	Inlet & Outlet – Right	STD	1/4"	BRZ
5	External Sensing – Right	STD	1/4"	DI, BRZ, CS, & SST
1, 2, 3 & 4	Inlet & Outlet – Right Inlet & Outlet – Left	85	1/4"	DI, BRZ, CS & SST
5 & 6	Double External Sensing	85	1/4"	DI, BRZ, CS & SST

Location	Description	Opt. No.	NPT - Size	Sp. Ch. Mat'l.
7	Spring Ch. – Inlet Side	25	1/4"	DI, BRZ, CS, SST

DIMENSION and WEIGHTS

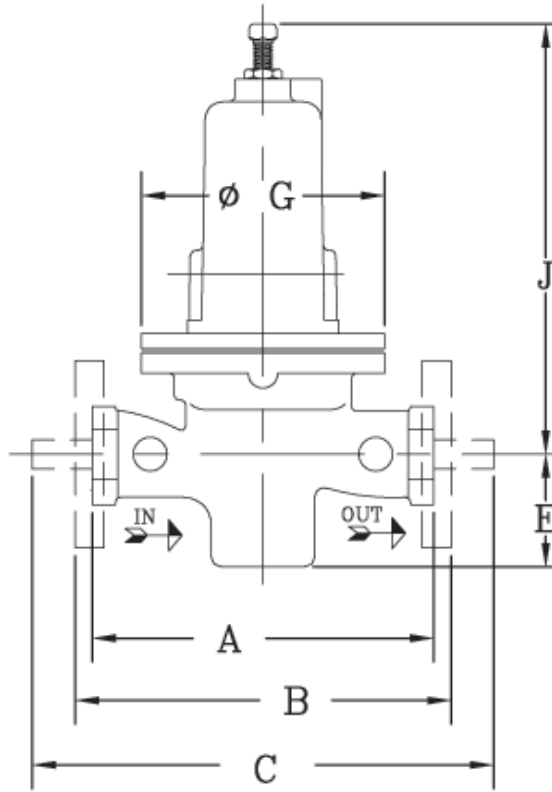

ENGLISH UNITS (in) (lbs)

METRIC UNITS (mm) (kg)

DIMEN.	END CONN.	BODY MAT'L	BODY SIZE						END CONN.	BODY SIZE					
			1/2", 3/4 & 1"	1-1/4" & 1-1/2"	2"	2-1/2"	3"	4"		DN15, DN20 & DN25	DN32 & DN40	DN50	DN65	DN80	DN100
A	NPT	DI, BRZ	6.00	9.88	9.88	-	-	-	NPT	152	251	251	-	-	-
		CS, SST, HC	8.25	9.88	9.75	-	-	-		209	251	248	-	-	-
B	125# FF	DI	-	-	-	10.88	11.75	13.88	125# FF	-	-	-	276	298	352
	250# RF	DI	-	-	-	11.50	12.50	14.50	250# RF	-	-	-	292	318	368
	150# FF	BRZ **	9.63	11.50 √	11.50	10.88	11.75	13.88	150# FF	246	292 √	292	276	298	352
	300# FF	BRZ **	9.63	11.50 √	11.50	11.50	12.15	14.50	300# FF	246	292 √	292	292	309	368
	150# RF	CS, SST	10.75	12.38 √	10.00	10.88	11.75	13.88	150# RF	273	314 √	254	276	298	352
		HC *			13.75	-	-	-				349	-	-	-
	150# RF ‡	CS, SST	14.00	14.00 √	14.00	-	-	-	150# RF ‡	356	356 √	356	-	-	-
	300# RF	CS, SST	10.75	12.38 √	10.50	11.50	12.50	14.50	300# RF	273	314 √	267	292	318	368
		HC *			14.25	-	-	-				362	-	-	-
	300# RF ‡	CS, SST	14.00	14.00 √	14.00	-	-	-	300# RF ‡	356	356 √	356	-	-	-
600# RF	CS, SST	10.75	12.38 √	11.25	12.25	13.25	15.50	600# RF	273	314 √	286	311	336	394	
600# RF ‡	CS, SST	14.00	14.00 √	14.00	-	-	-	600# RF ‡	356	356 √	356	-	-	-	
C	OPT-32 EXT NIPS	CS, SST	14.00	15.75	15.75	-	-	-	OPT-32 EXT NIPS	356	400	400	-	-	-
	OPT-41	SST	11.00	15.25	15.50	-	-	-	OPT-41	279	387	394	-	-	-
E	ALL	ALL	2.84	3.69	4.00	5.25	5.75	7.00	ALL	72	94	102	133	146	178
G	ALL	ALL	6.00	7.00	8.00	10.00	11.00	11.13	ALL	152	178	203	254	279	283
J	ALL	ALL	12.38	14.25	16.00	26.50	27.25	27.75	ALL	314	362	406	673	692	705
J Opt-80	ALL	ALL	17.00	17.50	19.00	-	-	-	ALL	432	444	483	-	-	-
WEIGHT	w/ Flanges	ALL	23	33	40	-	-	-	w/ Flanges	11	16	19	-	-	-
	w/ Flanges	ALL	28	43	52	100	175	190	w/ Flanges	13	20	24	45	79	86

* HC body material available in sizes 1", 1-1/2", & 2" ONLY.

** Flanged BRZ bodies available in sizes 1", 1-1/2", 2", 2-1/2", 3", & 4" ONLY.

√ Flange Connections not available for 1-1/4" size.

‡ Opt-34: Special 14" F to F Flange dimensions, CS and SST body material only.

Consult Factory for dimensions of ISO DIN Flanged units. (PN16, PN25, PN40)

NOTES

The contents of this publication are presented for informational purposes only, and while every effort has been made to ensure their accuracy, they are not to be construed as warranties or guarantees, express or implied, regarding the products or services described herein or their use or applicability. We reserve the right to modify or improve the designs or specifications of such product at any time without notice. Cashco, Inc. does not assume responsibility for the selection, use or maintenance of any product. Responsibility for proper selection, use and maintenance of any Cashco, Inc. product remains solely with the purchaser.

MODEL DA5 PRODUCT CODER 03/14/16

An "X" in POS 12 followed by a 5-digit control number overrides remaining selections.

D5

POS 3	POS 5	POS 6 & 7	POS 8	POS 10	POS 11	POS 12	POS 13	POS 14	POS 15	POS 16	POS 17	E
-------	-------	-----------	-------	--------	--------	--------	--------	--------	--------	--------	--------	---

POSITION 3 - SIZE		
Size	CODE	
in (DN)		
1/2" (15)	4	
3/4" (20)	5	
1" (25)	6	
1-1/4" (32)	7	
1-1/2" (40)	8	
2" (50)	9	
2-1/2" (65)	A	
3" (80)	B	
4" (100)	C	

^Not available with metal diaphragms

POSITION 5 - BODY & SPRING CHAMBER MATERIALS			
Materials	CODE	Materials	CODE
DI/DI	1	SST/DI	7
BRZ/DI	2	SST/CS *	9
BRZ/BRZ *** / ‡	B	SST/SST * / ****	A
BRZ/CS *	J	Dup SST / CS * / *****	F
BRZ/SST *	D	Dup SST / SST * / *****	L
CS/DI	4	Dup SST/Dup SST * / *****	M
CS/CS *	5	HC/CS ‡	G
LCC/LCC	6	HC/SST ‡	H
LCC/SST *	8		

* For Opt-80 Select CS or SST Spring Chamber Material except in Canada, use SST. See Position 11.
 *** Select for Opt-5 **** Select for Opt-36
 ***** Select for Sea water ‡ Sizes 1/2" - 2" Except No 1-1/4"

POSITION 6 & 7 - DIAPHRAGM AND SEAT MATERIALS						
Trim Material	Seat		O-ring/Seal		CODE	
	Diaphragm	Static	Dynamic			
17-4PH SST "P"	PA	BC	NBR	SST/TFE u-cup ^	P2	
	CTFE	BC	NBR	SST/TFE u-cup ^	P3	
	PA	NBR	NBR	SST/TFE u-cup ^	P6	
	PA	FK	FK	SST/TFE u-cup ^	P7 ‡	
	GF-TFE	FK	FK	SST/TFE u-cup ^	P8 ‡	
	V-TFE	FK	FK	SST/TFE u-cup ^	P9 ‡	
	PA	FKM	FKM	SST/TFE u-cup ^	PB	
	GF-TFE	FKM	FKM	SST/TFE u-cup ^	PD	
	V-TFE	FKM + TFE	SST /TFE u-cup √	SST/TFE u-cup ^	PE	
	GF-TFE	3-ply	RTFE	SST/TFE u-cup \$	PF	
	GF-TFE	3-ply	RTFE	PRA \$	PG	
	PA	NBR	NBR	TFE+NBR CP	PH	
	PA	EPR	EPR	TFE+EPR CP ^	PJ	
	PA	FK	FK	TFE+FK CP ^	PK	
	GF-TFE	FKM	FKM	TFE_FKM CP	PL	
	FKM	FKM	FKM	SST/TFE u-cup	PZ	
	Hastelloy "H"	PA	FK	FK	Hast-C/TFE u-cup	H7
		V-TFE	FK	FK	Hast-C/TFE u-cup	H9
GF-TFE		FKM	FKM	Hast-C/TFE u-cup	HD	
Monel "M"	PA	FK	FK	SST/TFE u-cup ‡ ^	M7 ‡	
	V-TFE	FK	FK	SST/TFE u-cup ^	M9 ‡	
	V-TFE	FKM-TFE	SST/TFE u-cup √	SST/TFE u-cup	ME	
	V-TFE	FKM	FKM	Hast-C/TFE u-cup	MQ	
316L SST "S"	FKM	FKM	FKM	SST/TFE u-cup	MZ	
	PA	FK	FK	SST/TFE u-cup	S7 ‡	
	V-TFE	FK	FK	SST/TFE u-cup	S9 ‡	
	PA	BE-CU *	SST/TFE u-cup	SST/TFE u-cup	SM	
	V-TFE	BE-CU *	SST/TFE u-cup	SST/TFE u-cup +	SN	
	PA	BC	V-TFE	ELG/TFE u-cup ^	NP ‡	
	PA	NBR	NBR	ELG/TFE u-cup	NR	
	PA	FKM	FKM	ELG/TFE u-cup	NS	
NACE	FKM	FKM	FKM	ELG/TFE u-cup	NF	
	CTFE	NBR	V-TFE	ELG/TFE u-cup	NT ‡	
	V-TFE	BC	V-TFE	ELG/TFE u-cup ^	NV ‡	
	PA	FK	FK	SST/TFE u-cup ‡ ^	T7 ‡	
	V-TFE	FK	FK	SST/TFE u-cup ^	T9 ‡	
	PA	BE-CU *	SST/TFE u-cup	SST/TFE u-cup	TM	
	V-TFE	BE-CU *	SST/TFE u-cup	SST/TFE u-cup +	TN	
	17-4PH/ Monel/17-4PH "T"	PA	FK	FK	SST/TFE u-cup ‡ ^	T7 ‡
V-TFE		FK	FK	SST/TFE u-cup ^	T9 ‡	
PA		BE-CU *	SST/TFE u-cup	SST/TFE u-cup	TM	
V-TFE		BE-CU *	SST/TFE u-cup	SST/TFE u-cup +	TN	

‡ For GOX service, PA seats allowed in BRZ Bodies only.
 * 2-1/2" - 4" sizes are not available with metal diaphragm. + Use for Opt-5 or -36.
 ‡ For Low Ambient Temperatures (See DAG-5 & -14 for Min. Temperatures)
 ^ Only trims that may be used with Opt-80. √ Sizes 2-1/2"-4" use V-TFE static seal
 \$ For Steam applications Max Press < 125 psig. Abbreviations defined on page 2

POSITION 8 - Product Classification Under European "Pressure Equipment Directive"		
PRODUCT DESTINATION	HAZARD CATEGORY	CODE
Anywhere except Europe	N/A	7
European Countries * (CE Mark does not apply to DN25 and below)	Sound Engineering Practice (SEP)	S
	CE Marked Hazard Cat I or II	E

* For products to be placed in service in Europe - Ref to Directive 97/23/EC. Forward Completed "EU" Application Recorder prior to quotation. (Without Recorder-Processing of Purchase Order will be delayed). Contact Cashco for Assistance.

POSITION 10 - END CONNECTIONS / ASME								
Size	Material	Method	End Conn	CODE	End Conn	CODE	End Conn	CODE
1/2" - 2"	ALL	-	NPT	1	-	-	-	-
2-1/2" - 4"	DI	Integral	125#FF	2	250#RF	3	-	-
1", 1-1/2" - 4"	BRZ	Integral	150#FF	6	300#FF	7	-	-
1/2" - 3/4"	CS,SST	Opt-30						
1" - 4"	CS-SST	Integral *	150#RF	4	300#RF	5	600# RF	8
1" - 2"	HC	Opt-30 *						
1/2" - 2"	ALL	Opt-31	BSP	P	-	-	-	-
1/2" - 2"	CS, SST	Opt-32	Extended Nipples		E			
1/2" - 2" (14" F to F)	CS, SST	Opt-34 *	150#RF	V	300#RF	W	600#RF	Y
1/2" - 1", 1-1/2" - 2	SST	Opt-41	Non-High Purity Tube Ends		T			

END CONNECTIONS FOR ISO DIN FLANGES								
DN15-25, 40, 50			PN40 FF - will mate with PN16, 25 and 40		J			
DN65-100	BRZ	Integral	PN16 FF	K	PN25 FF	L	PN40 FF	M
DN15-25, 40, 50	CS, SST, HC	Opt-30	PN40 RF - will mate with PN16, 25 and 40		D			
DN65-100	CS, SST	Integral	PN16 RF	A	PN25 RF	C	PN40 RF	G

* Flanges Not Available for 1-1/4" (DN32) size.
 ** 1" size w/ 600# RF CS, or SST has weld-on flanges Opt-30 (Not available in HC material)

POSITION 13 - FEATURE OPTIONS		
No Option	-	0
TFE Diaphragm Cover.	-9	2
Cryogenic Constr. (Select Cleaning Spec. Opt.-55 or -56 from Position 16.	-5 or -36	C

POSITION 11 - RANGE SPRINGS							
Body Size	Pressure Range		CODE	Body Size	Pressure Range		CODE
	psig	barg			psig	barg	
1/2" 3/4" & 1" (DN 15, 20 & 25)	1-5 ^	.07-.34	1	2" (DN50)	1-5 ^	.07-.34	1
	1-10 ^	.07-.68	S		1-10 ^	.07-.68	S
	5-20	.34-1.3	A		5-15	.34-1.0	M
	10-35	.68-2.4	B		10-30	.68-2.0	N
	20-80	1.3-5.5	C		15-50	1.0-3.4	P
	30-150	2.0-10.3	D		30-90	2.0-6.2	Q
	70-200	4.8-13.7	E		50-150	3.4-10.3	R
	100-300	6.8-20.6	F		80-225 *	5.5-15.5	Z
	200-450 *	13.7-31.0	G		80-275 *	5.5-18.9	4
1-1/4" 1-1/2" (DN32 40)	1-5 ^	.07-.34	1	2-1/2" 3" & 4" (DN65, 80 & 100)	1-10	.07-.68	S
	1-10 ^	.07-.68	S		5-20	.34-1.3	A
	5-20	.34-1.3	A		10-40	.68-2.7	T
	15-45	1.0-3.1	H		10-70	.68-4.8	J
	10-70	.68-4.8	J		40-125	2.7-8.6	K
	40-175	2.7-12.0	2		50-225	3.4-15.5	3
	70-200	4.8-13.7	E				
	100-350 *	6.8-24.1	Y				
100-400 *	6.8-27.5	6					

* Opt-80 - High Inlet Pressure - See Position 5.
 ^ Comp diaphragm only.

POSITION 12 - SENSING & FLOW DIRECTION	
Option	Flow To Open (Reverse)
	CODE
Internal	5
External	6
Large Internal	8
Ratio Loaded	R
For Special Construction Contact Cashco for Special Code	X

POSITION 14 - SPRING CHAMBER OPTIONS		
No Option	-	0
1/4" (DN8) NPT Vent Tap.	-25	E
Vent Screen (Includes Opt.-25).	-25S	H

POSITION 15 - BODY OPTIONS		
No Option	-	0
Second Set 1/4" (DN8) FNPT Pressure Taps & Plugs.	-85	T

POSITION 16 CERTIFICATE OPTIONS		
No Option	-	0
NACE CONST: CS/CS, LCC/LCC, LCC/SST, SST/CS, SST/SST All Sizes Except 1-1/4" (DN32) Per MR0175.	-40	J
SPECIAL CLEANING: Per Cashco Spec #S-1134. W/ properly selected mat'ls. Suitable for Oxygen Service. BRZ or SST body material.	-55	M
SPECIAL CLEANING: Per Cashco Spec #S-1542.	-56	N
SPECIAL CLEANING: Per Cashco Spec #S-1589 Cl2 Service.	-57	P

POSITION 17 PAINT OPTIONS		
No Option	-	0
Epoxy Painted Per Cashco Spec #S-1547.	-95	W
Epoxy Painted Per Cashco Spec #S-1687 OFFSHORE Applic.	-95OS	Y

Cashco, Inc.
 P.O. Box 6
 Ellsworth, KS 67439-0006
 PH (785) 472-4461
 Fax. # (785) 472-3539
 www.cashco.com
 email: sales@cashco.com
 Printed in U.S.A.

Cashco GmbH
 Handwerkerstrasse 15
 15366 Hoppegarten, Germany
 PH +49 3342 30968 0
 Fax. No. +49 3342 30968 29
 www.cashco.com
 email: germany@cashco.com

Cashco do Brasil, Ltda.
 Al.Venus, 340
 Indaiatuba - Sao Paulo, Brazil
 PH +55 11 99677 7177
 Fax. No.
 www.cashco.com
 email: brazil@cashco.com