



working with you

Alpha Place, Garth Road  
Morden, Surrey  
SM4 4LX England

(T): +44 208 337 2945  
(E): sales@croxsons.com  
[WWW.CROXSONS.COM](http://WWW.CROXSONS.COM)

Registered Office as above. Registered No: 71941

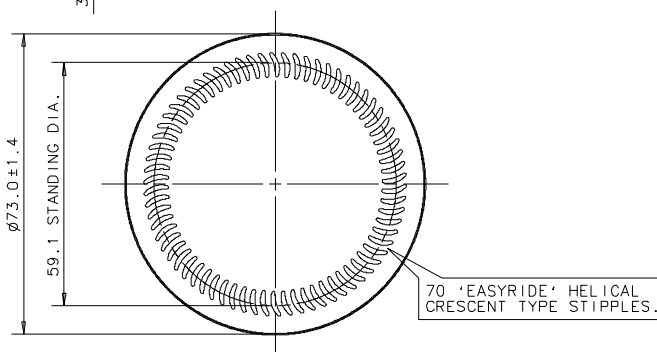
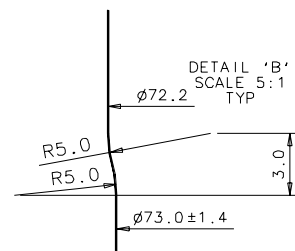
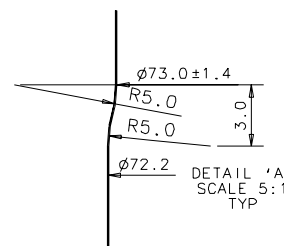
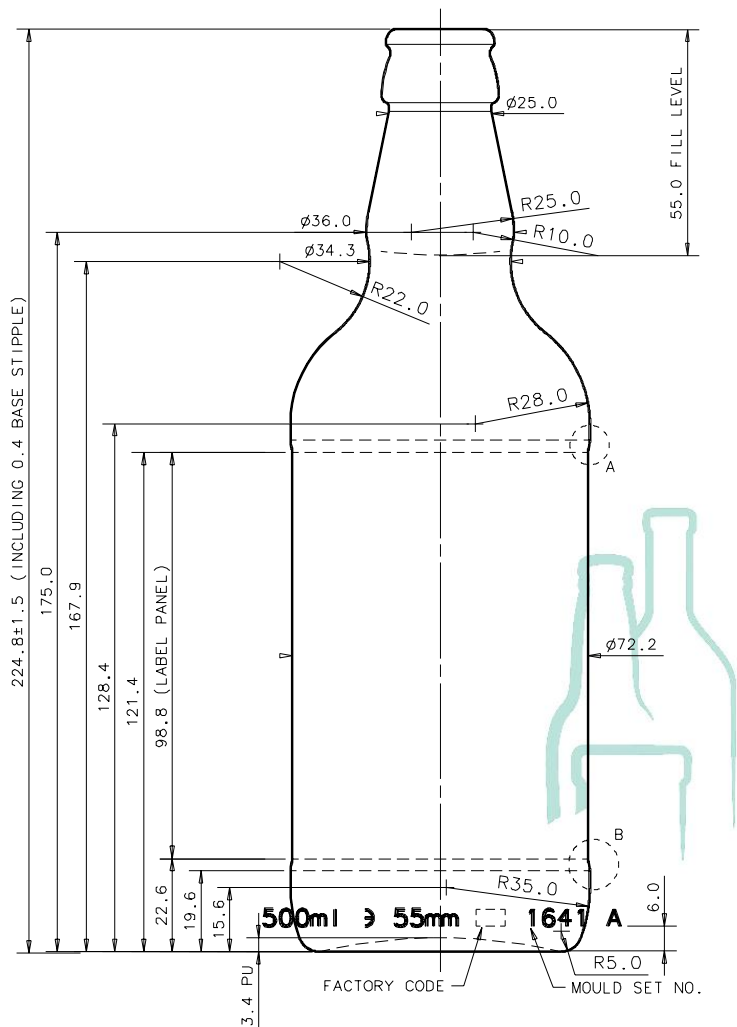

DESCRIPTION:	<b>500ml Lightweight AMC Beer</b>			ITEM CODE:	CRQ1641
COLOUR:	White Flint / Amber			WEIGHT:	319 g
NOMINAL CAPACITY:	500 ml	BRIMFULL CAPACITY:	525 ± 10ml	CLOSURE:	26mm Standard Crown
HEIGHT:	224.8 ± 1.5mm	DIAMETER:	73.0 ± 1.4mm	FILL HEIGHT:	55mm
LABEL PANEL:	98.8mm	CARBONATION:	3.0 bar	VACUITY:	25.0ml   5.0%
PALLET HEIGHT:	1.29m	PALLET WEIGHT:	410kg	UNITS PER PALLET:	1170 (5 tiers)
DRAWING CHECKED:	<i>Jim Croxson</i>	DATE CHECKED:	13/11/09	DRAWING REF:	CRQ1641.01

All measurements are approximate unless tolerances stated, E&OE. Clients should run trials and check physical samples prior to any full scale production.