

MODEL SLR-2

PRESSURE REDUCING REGULATOR with NON-Relieving Loader 1/2" – 4" (DN15 – 100)



APPLICATIONS

“Designed as a gaseous service regulator. Excellent for atmospheric industrial gases – GN₂, GOX, Ar, He, H₂, CO₂ – as well as natural gas. Can be used as a utilities air regulator. Also for use in corrosive and non-corrosive chemical gas services are possible with broad materials range.

Model SLR-2 is high performance, pressure loaded diaphragm-type, flow-to-open pressure reducing regulator. Design includes an internal pressure balancing piston-cylinder that provides high flow capacity and high pressure drop capability. Performance meets or exceeds that of competitive pressure loaded or pilot-operated designs. A non-relieving pressure regulator "loader" is bracket mounted to the top of the dome. The set point of the loader controls the upstream supply pressure into the dome to maintain the desired downstream pressure of the SLR-2. Pressure in the dome will constantly bleed out through a filter and check valve which is piped back into the outlet of the body of the pressure reducing regulator.

FEATURES

- Versatile:** Five basic materials and multiple trim material combinations to select from. Multiple methods of pressure loading.
- Tight Shutoff:** Multiple composition materials provide Class IV or VI inboard leakage rates. Designed as a soft-seated valve.
- Capacity:** Highest in the industry. Allows smaller body sizes than competitors in majority of applications.
- Droop:** Highly accurate outlet pressure control, due to absence of range spring in design, provides almost zero “droop effect”.
- Trim Design:** FTO and pressure balancing allows for higher inlet pressure. Results in unmatched sensitivity and stability. Internals are cage-contained within easily removable quick change trim.
- Rangeability:** Basic valve gives outstanding rangeability due to close tolerances, balanced trim, and a broad range of elastomeric and metallic diaphragms and soft seats. Can be as high as 2000:1.
- Heavy-Duty Guiding:** Both top and bottom guided to maintain stability and increased diaphragm life.
- Failure Position:** Fails closed on loss of loading pressure.

STANDARD / GENERAL SPECIFICATIONS

Body / Cover Dome Materials

DI/DI	BRZ/BRZ	SST/DI
CS/DI	BRZ/DI	SST/CS
CS/CS	SST/SST	

DI = Ductile Iron CS = Carbon Steel BRZ = Bronze
SST = Stainless Steel

Body Sizes

1/2", 3/4", 1", 1-1/4", 1-1/2", 2", 2-1/2", 3", 4".
(DN15, 20, 25, 32, 40, 50, 65, 80, 100)

End Connections

Standard: Female NPT.
ASME Flanged: 125#, 150#, 250#, 300#, 600#;
DIN Flanged: PN16, PN25, PN40;
(Integral Flanged Body unless listed under Opt.-30)
Opt-31: British Standard Pipe Threads.
Opt-34: 14" Face to Face Flange Dimension.

Max. Useable Cv

See TABLE 7 for Wide Open Cv Limits.

Body Size		Comp. Cv	Body Size		Comp. Cv
in	(DN)		in	(DN)	
1/2"	(15)	3.6	2"	(50)	54
3/4"	(20)	7.2	2-1/2"	(65)	81
1"	(25)	13.5	3"	(80)	108
1-1/4"	(32)	20.7	4"	(100)	198
1-1/2"	(40)	27.0			

METRIC CONVERSION FACTOR: $Cv / 1.16 = kv$

Max Operating Pressure

3600 psig (248 Barg).

See Tables DAG-1A thru-1H for design P vs. T limits

Outlet Pressure Range

0.5 - 1250 psig (0.03 - 86.1 Barg).
Multiple springs - ranges dependent on selection of the unloader. See Position 13 on the coder.

Function of diaphragm material. See TABLE 6.

Pressure Drop Limits

5–1500 psid (.34 – 103.4 Bard)
Function of service fluid, base trim material, diaphragm and dynamic seal design. See TABLES -2, -3, -4 & -6.

Temperature Range

-50° to +400°F (-46° to +204° C)
Limited by body/cover dome/diaphragm material combinations, and by elastomeric seat, static seal, dynamic seal – materials. See TABLE 1A through 1F and TABLE 5.
Alternate "CS" Mat'l - Steel - ASTM A352 Gr. LCC -
Minimum temperature -50 °F (-46 °C).

Inboard Leakage Rate

See TABLE 10

Lower Piston Spring

No lower piston spring; $P_2 = P_{Load}$.
Lower piston spring required; $P_2 < P_{Load}$.
See TABLE-9 for available spring ranges.
NOTE: Use a lower piston spring with the following applications:
1. When decaying inlet may reach 0 psig.

Optional Constructions

<u>Opt-30:</u> Weld-on Flanges <u>Opt-31:</u> BSP End Conns. <u>Opt-34:</u> Special 14" F to F <u>Opt-55:</u> Oxygen Cleaned <u>Opt-56:</u> Special Clean	<u>Opt-81:</u> Full Diaph Support <u>Opt-85:</u> Extra Set Pressure Taps <u>Opt-95:</u> Epoxy Paint <u>Opt-95OS:</u> Epoxy Paint
---	--

Loader Specifications

Globe Design. 1/4" Size, NPT connections. Available in Aluminum, Brass or SST materials of construction with **NON-Relieving** feature. Range springs from 0.5 to 1250 psig. (See Position 13 on the coder.)

Loader Material	Loader Max. Pressure			
	Inlet		Outlet	
	psig	Barg	psig	Barg
ALUM	500	34.5	400	27.5
BR	3600	248	750	51.7
SST	3600	248	750	51.7
SST w/ SLR-2 - Opt-81	3600	248	1250	86.1

ABBREVIATIONS

FK = Fluorosilicone	NBR = Buna-N	PTFE = Polytetrafluoroethylene
FKM = Fluorocarbon	RTFE = Brz-fill TFE	V-TFE = Virgin TFE
EPR = Ethylene Propylene	GF-TFE = Glass-fill TFE	CTFE = Chlorotrifluoroethylene
BC = Neoprene	PA = PolyAll	

MATERIAL SPECIFICATIONS

Body

DI – ASTM A395
CS – ASTM A216, Grade WCB.
 Alternate ASTM A352 Grade LCC
BRZ – ASTM B62, Alloy 83600,
SST – ASTM A351, Grade CF3M.

See TABLES 1A through 1F for material specs.

Cover Dome

DI – ASTM A395
CS – ASTM A216, Grade WCB.
 Alternate ASTM A352 Grade LCC
BRZ – ASTM B62, Alloy 83600,
SST – ASTM A351, Grade CF3M

Metallic Trim *

Plug, Cage: 17-4PH SST, 316L SST,
 Nickel-Copper Alloy (Monel[†]),

PART	TRIM DESIGNATION			
	P	M	S	T
Plug	17-4 PH SST	Monel †	316L SST	17-4 PH SST
Guide Bearing	17-4 PH SST	Monel †	316L SST	17-4 PH SST
Cage	316L SST	Monel †	316L SST	Monel †
Body Bushing	17-4PH SST	Monel †	Monel †	Monel †

Diaphragm *

Elastomeric – BC, EPR, FKM, FK, NBR, FKM+TFE.

Seat *

PolyAll, V-TFE, GF-TFE, CTFE, BC, NBR

Static Seals (See Fig. 1) *

NBR, FKM, FK, EPR - o-ring
 SST/TFE (1/2"-2") (DN15-50) sizes,
 V-TFE (2-1/2"-4") (DN65-100) sizes.

Dynamic Seals (See Fig. 1) *

Type OR - NBR, FKM, FK, EPR - o-ring seal.
Type UC – V-TFE u-cup seal w/ 316L SST energizer
 – V-TFE u-cup seal w/ Elgiloy energizer
Type CW – TFE cap seal with o-ring energizer
 (o-ring material same as static seal)
 and GF-TFE wiper backup seal.

Painting

Standard: All non-corrosion resistant portions to be painted with corrosion resistant epoxy paint per Cashco Spec #S-1606.

Alternate: See Opt-95 or Opt-95OS.

* See Product Coder for acceptable combinations.
 † Monel[™] and Inconel[®] are registered trade names:
 Monel[™] is a mark owned by International Nickel Co.
 Inconel[®] is a mark owned by International Nickel Co.

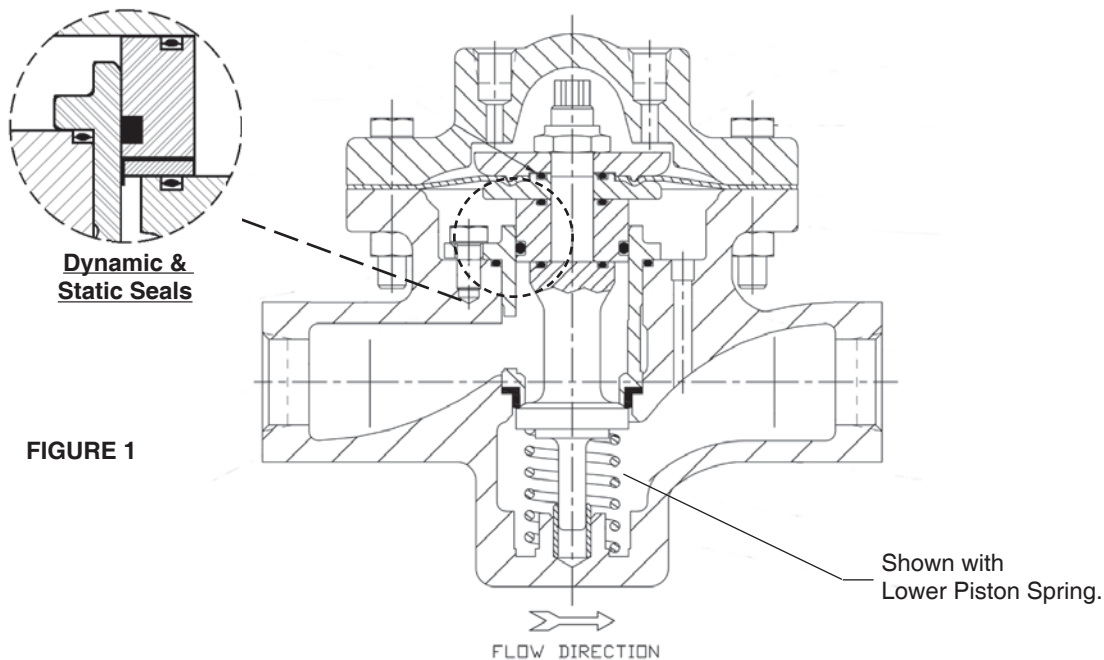

OPTION SPECIFICATIONS

OPT-30: **WELD FLANGED CONNECTIONS.** CS, or SST body materials only. 1/2" – 1-1/2" (DN15–40) body sizes only (no 1-1/4" (DN32) size). Weld-on flange of same general chemistry as body.

Weld-On Flanges		
Sizes	Body Material	ASME Pressure Class
1/2" - 3/4"	CS, SST	150, 300, 600
1"	CS, SST	600
Sizes	Body Material	ISO Pressure Class
DN15-50	CS, SST	PN40 RF
DN65-100	CS, SST	PN16, 25, 40 RF

NOTES: 1. The body P vs. T ratings are the limiting variables for flanged end connections, unless further restricted by ASME B16.5.
2. No post-weld stress relieving performed.

OPT-31: **BSP END CONNECTIONS.** British Standard Pipe threads per ISO 7/1; used as an alternate to NPT ends. 1/2" – 2" (DN15–50) sizes only.

OPT-34: **SPECIAL 14" FACE TO FACE DIMENSION FOR FLANGED END CONNECTIONS.** Sizes 1/2" - 1", 1-1/2" & 2" only. See Opt-30 for standard face to face dimension.

OPT-40: **NACE CONSTRUCTION.** Internal wetted portions meet NACE Std. MR0175 for application in sour gas/crude service. Exterior of unit to not be directly buried, insulated, or otherwise denied direct atmospheric exposure. CS/CS, LCC/LCC, LCC/SST, SST/CS, or SST/SST body/cover dome materials only. 316L SST trim material only. ELG/TFE U-cup dynamic seals. Available in all end connections. All welded portions heat treated to stress relieve weldments.

OPT-55: **SPECIAL CLEANING - GOX.** BRZ or SST body materials only. Cleaning, assembly and packaging per Cashco Spec #S-1134, making unit suitable for Oxygen Service. **NOTE: Design Pressure Rating shall not exceed 375 psig (25.8 Barg) when body/topworks material is SST and process medium is oxygen.**

OPT-56: **SPECIAL CLEANING.** Cleaning per Cashco Spec. No. S-1542 for all body/cover dome materials. Higher cleaning level than std. commercial cleaning. NOT suitable for Oxygen Service.

OPT-81: **FULL DIAPHRAGM SUPPORT CONSTRUCTION.** Incorporates top and bottom diaphragm support that allows reaching higher fluid pressures on the underside and topside of diaphragm. Sizes 1/2"-2" (DN15 - 50) only. See Table 6.

OPT-85: **PRESSURE TAPS.** Provides second set of inlet and outlet 1/4" (DN8) - FNPT taps with plugs (same basic material as body) on backside of body. Includes second external sensing port tap. See Figure F2 for details on tap location for both STD. and Opt-85.

OPT-95: **EPOXY PAINT.** Special epoxy painting of all non-corrosion resistant external surfaces per Cashco Spec #S-1547. Utilized in harsh atmospheric conditions.

OPT-95OS: **EPOXY PAINT.** Special epoxy painting of all non-corrosion resistant external surfaces per Cashco Spec #S-1687. Utilized in OFFSHORE atmospheric conditions.

TECHNICAL SPECIFICATIONS APPENDIX INDEX

<u>TABLE</u>	<u>TITLE</u>	<u>PAGE</u>
1A	DI – Press vs Temp vs End Conn Ratings	5
1B	BRZ – Press vs Temp vs End Conn Ratings	6
1C	CS – Press vs Temp vs End Conn Ratings - Design Inlet	7
1D	Design Outlet	7
1E	SST – Press vs Temp vs End Conn Ratings – Design Inlet	8
1F	Design Outlet	8
2	Max Pressure Drop - Comp Seat	9
3	Max Pressure Drop - Dynamic Seal Design	9
4	Max Pressure Drop - Basic Trim Mat'ls	9
5	Temperature Limits – Elastomer Mat'ls	10
6	Max Diaphragm Rating	10
7	Reducer Max Capacity - Plug Wide Open	11
8	Pressure Loading System Tubing & Fitting Maximum Containment Pressure Process or Auxiliary Fluids	11
9	Reducer Lower Piston Spring range	11
10	Inboard Leakage Ratings	12
11	Reducer Recommended Velocity Limits	12
12	Max Recommended Noise Limits	12
13	Recommended Internal Materials - Gases Supplement - Chemical Resistance	13
14	ISR Effect	14
 FIGURE		
F1	Dynamic/Static Seals	14
F2	Location of Body Taps	15

TABLE 1A
DI – DUCTILE IRON
BODY / TOPWORKS MATERIAL SPECIFICATIONS
DESIGN PRESSURE vs. TEMPERATURE vs. END CONNECTION RATINGS
(To ASME B16.1 for Flanged and B16.4 for NPT Connections per Cast Iron Rating)

Material Specifications (Body / Topworks)		End Connection – Inlet & Outlet				
Description (Abbr.)	ASTM No.	Temperature °F	Containment Pressure – psig			
			End Connection – Pressure Class			
			NPT	125# FF	250# RF	
DI/DI (Note 1)	A395/ A395	-20° to +150°	400	200	500	
		200°	370	190	460	
		225°	355	180	440	
		250°	340	175	415	
		300°	310	165	375	
		350°	300	150	335	
		400°	250	140	290	
		406°	250	140	290	
		Temperature °C	Containment Pressure – Barg			
			End Connection – Pressure Class			
				NPT	125# FF	250# RF
			-29° to +65°	27.6	13.8	34.5
			107	24.5	12.5	30.2
			120°	23.4	12.1	28.7
			150°	21.2	11.2	25.7
			177°	19.2	10.6	23.8
204°	17.5	9.6	20.3			

NOTE 1: Whenever body and topworks materials are mixed, the P vs. T ratings that should be applied are those which are lowest of the two materials.

Example: CS body, DI topworks; NPT end connections, 200°F temperature.

Because the topworks is not “end flanged”, use DI limits of "400 PSIG CWP 370/200F" from above to compare to CS limits from Table 1C value. The DI limits are lower, so ratings from Table 1A MUST be used as the limits.

TABLE 1B
BRZ – BRONZE
BODY / TOPWORKS MATERIAL SPECIFICATIONS

DESIGN PRESSURE vs. TEMPERATURE vs. END CONNECTION RATINGS
(Per ASME B16.24 for Flanged and B16.15 for NPT Connections)

Material Specifications (Body / Topworks)		End Connection – Inlet & Outlet					
Description (Abbr.)	ASTM No.	Temperature °F	Containment Pressure –psig				
			End Connection – Pressure Class				
			NPT	150# FF	300# FF		
BRZ/BRZ (Note 1)	B62, Alloy C83600/B62, Alloy C83600	-50° to +150° *	700 † / 500	225	500		
		175°	390	220	480		
		200°	385	210	465		
		225°	375	205	445		
		250°	365	195	425		
		300°	335	180	390		
		350°	300	165	350		
		400°	250	150	315		
		406°	250	150	315		
				Containment Pressure – Barg			
				End Connection – Pressure Class			
				NPT	150# FF	300# FF	
				-46° to +65° *	48.3 † / 34.5	15.5	34.5
				107°	25.8	14.0	30.8
				120°	25.1	13.5	29.5
				150°	23.0	12.4	26.8
				177°	20.4	11.3	24.0
		204°	17.8	10.3	21.4		

† Use 700 psig (48.2 Barg) inlet / 500 psig (34.4 Barg) outlet at 150°F as maximum limits.

NOTE 1: Whenever body and topworks materials are mixed, the P vs. T ratings that should be applied are those which are lowest of the two materials.

Example: BRZ body, DI topworks; NPT end connections, ambient temperature.
Because the topworks is not “end flanged”, use the DI limits of “400 PSIG CWP 370/200F” from TABLE 1A to compare to above TABLE 1B values. The DI limits are lower, so ratings from TABLE 1A MUST be used as the limits.

Body Material Specifications

Cast Steel A216 Gr. WCB or Steel Weldment A216 Gr. WCB w/ forged flanges A105

Alternate Material: Cast Steel A352 Gr. LCC or Steel Weldment A352 Gr. LCC w/ forged flanges A350 Gr. LF6 Class 2

Topworks Material Specifications

Cast Steel A216 Gr. WCB

Alternate Material: Cast Steel A352 Gr. LCC

DESIGN PRESSURE vs. TEMPERATURE vs. END CONNECTION RATINGS (Per ASME B16.5 and B16.34) See NOTE 1

TABLE 1C DESIGN INLET PRESSURE in PSIG (BARG)					
CONSTRUCTION	END CONNECTIONS				
	STD DIAPHRAGM	ALL			Opt-81 (Full Support Diaph.)
DESIGN TEMP. RANGE: Deg F (Deg C) **	NPT, BSP	600#	150#	300#	NPT, BSP
-20 to +100 (-29 to +38)	1480 (102.1)	1480 (102.1)	285 (19.6)	740 (51.1)	3705 (255.3)
-20 to +200 (-29 to +93)	1360 (94.2)	1360 (94.2)	260 (17.9)	680 (47.1)	3375 (235.5)
-20 to +300 (-29 to +149)	1310 (90.3)	1310 (90.3)	230 (15.8)	655 (45.1)	3280 (225.6)
-20 to +400 (-29 to +204)	1265 (87.3)	1265 (87.3)	200 (13.7)	635 (43.6)	3170 (218.3)

** Alternate Mat'l: ASTM 352 Gr. LCC Minimum Temperature -50 °F (-46 °C).

TABLE 1D DESIGN OUTLET PRESSURE in PSIG (BARG)				
CONSTRUCTION	END CONNECTIONS			
	STD DIAPHRAGM	ALL		Opt-81 (Full Support Diaph.)
DESIGN TEMP. RANGE: Deg F (Deg C) **	NPT, BSP, 600#	150#	300#	NPT, BSP, 600#
-20 to +100 (-29 to +38)	750 (51.7)	285 (19.6)	740 (51.1)	1350 (93.0)
-20 to +200 (-29 to +93)	680 (47.1)	260 (17.9)	680 (47.1)	1350 (93.0)
-20 to +300 (-29 to +149)	655 (45.1)	230 (15.8)	655 (45.1)	1310 (90.3)
-20 to +400 (-29 to +204)	635 (43.6)	200 (13.7)	635 (43.8)	1265 (87.3)

** Alternate Mat'l: ASTM 352 Gr. LCC Minimum Temperature -50 °F (-46 °C).

NOTE 1: These pressure ratings may be further derated by limitations thru the Pressure Equipment Directive (97/23/EC-May '97). Whenever body and topworks are mixed, the P vs. T ratings that should be applied are those which are lowest for the two materials.

Example: 600 lb. RF flanged steel body, full support diaphragm construction, at 200 deg F maximum temp would have a preliminary inlet to 3375 psig and outlet to 1350 psig, but if fitted with a ductile iron topworks pressure rating is only 370 psig. Must derate both the inlet and outlet to 370 psig. (Note: Topworks pressure rating, same as NPT design outlet pressure rating for the selected topworks material and diaphragm type.

Body Material Specifications

Cast Stainless Steel A351 Gr.CF3M or Stainless Steel Weldment A315 Gr. CF3M w/ forged flanges A182 Gr. F 316L

Topworks Material Specifications

Cast Stainless Steel A351 Gr.CF3M

DESIGN PRESSURE vs. TEMPERATURE vs END CONNECTION RATINGS (Per ASME B16.5 and B16.34) See NOTE 1

TABLE 1E DESIGN INLET PRESSURE in PSIG (BARG)					
CONSTRUCTION	END CONNECTIONS				
	STD DIAPHRAGM	ALL			Opt-81 (Full Support Diaph.)
DESIGN TEMP. RANGE: Deg F (Deg C)	NPT, BSP	600#	150#	300#	NPT, BSP
-50 to +100 (-46 to +38)	1440 (99.3)	1440 (99.3)	275 (19.0)	720 (49.6)	3600 (248.2)
-20 to +200 (-29 to +93)	1240 (86.1)	1240 (86.1)	235 (16.5)	620 (43.0)	3095 (215.1)
-20 to +300 (-29 to +149)	1120 (77.1)	1120 (77.1)	215 (14.8)	560 (38.6)	2795 (192.9)
-20 to +400 (-29 to +204)	1025 (70.9)	1025 (70.9)	195 (13.6)	515 (35.5)	2570 (177.4)

TABLE 1F DESIGN OUTLET PRESSURE in PSIG (BARG)				
CONSTRUCTION	END CONNECTIONS			
	STD DIAPHRAGM	ALL		Opt-81 (Full Support Diaph)
DESIGN TEMP. RANGE: Deg F (Deg C)	NPT, BSP, 600#	150#	300#	NPT, BSP
-50 to +100 (-46 to +38)	625 (43.0)	275 (19.0)	625 (43.0)	1125 (77.5)
-20 to +200 (-29 to +93)	620 (42.3)	235 (16.5)	620 (42.3)	1125 (77.5)
-20 to +300 (-29 to +149)	560 (38.6)	215 (14.8)	560 (38.6)	1120 (77.0)
-20 to +400 (-29 to +204)	515 (35.5)	195 (13.6)	515 (35.5)	1025 (70.9)

NOTE 1: These pressure ratings may be further derated by limitations thru the Pressure Equipment Directive (97/23/EC-May '97). Whenever body and topworks are mixed, the P vs. T ratings that should be applied are those which are lowest for the two materials. **Example:** 300 lb. RF flanged SST body, standard diaphragm construction, at 200 deg F maximum temp would have a preliminary inlet and outlet to 620 psig, but if fitted with a ductile iron topworks pressure rating is only 400 psig. Must derate both the inlet and outlet to 400 psig. (Note: Topworks pressure rating, same as NPT design outlet pressure rating for the selected topworks material and diaphragm type.

The ratings are the same as above, if substitute steel topwork material.

300# Flanges are derated due to the bolting for these products.

**TABLE 2
MAXIMUM PRESSURE DROP FOR
COMPOSITION SEATS**

Body Size		Max. Pressure Drop - psid (Bard)			
		Seat Material			
in	(DN)	BC, NBR, POLYALL		GF-TFE	
1/2" – 1"	(15-25)	750	(51.7)	1000	(68.9)
1-1/4" – 1-1/2"	(32-40)	600	(41.3)	900	(62.0)
2"	(50)	600	(41.3)	750	(51.7)
2-1/2" – 4"	(65-100)	600	(41.3)	750	(51.7)
		V-TFE		CTFE	
1/2" – 1"	(15-25)	600	(41.3)	3000	(206.9)
1-1/4" – 1-1/2"	(32-40)	600	(41.3)	3000	(206.9)
2"	(50)	600	(41.3)	2000	(137.9)
2-1/2" – 4"	(65-100)	450	(31.0)	1500	(103.4)

**TABLE 3
MAXIMUM PRESSURE DROP FOR
DYNAMIC SEAL DESIGNS**

Body Size		Max. Pressure Drop - psid (Bard)					
		Dynamic Seal Design					
in	(DN)	"OR" – O-RING		"CW" – TFE CAP w/WIPER		"UC" - U-CUP	
1/2" – 1"	(15-25)	750	(51.7)	600	(41.3)	3000	(206.9)
1-1/4" – 1-1/2"	(32-40)	750	(51.7)	600	(41.3)	3000	(206.9)
2"	(50)	750	(51.7)	600	(41.3)	3000	(206.9)
2-1/2" – 4"	(65-100)	750	(51.7)	600	(41.3)	3000	(206.9)

**TABLE 4
MAXIMUM PRESSURE DROP FOR
BASIC TRIM MATERIAL**

Body Size		Max Pressure Drop - psid (Bard)							
		Basic Trim Material							
in	(DN)	"P" – 17-4PH SST		"S" – 316L SST		"M" – Monel		"T" – Hybrid *	
1/2" – 2"	(15-50)	3000	(206.9)	800	(55.1)	1500	(103.4)	3000	(206.9)
2-1/2" – 4"	(65-100)	3000	(206.9)	800	(55.1)	1500	(103.4)	3000	(206.9)

* 17-4PH SST plug & piston, Monel cage.

**TABLE 5
TEMPERATURE LIMITS
FOR ELASTOMERIC MATERIALS**

Elastomer			T Maximum		T Minimum	
	ID	Description	°F	(°C)	°F	(°C)
	Seats	PolyAll	Proprietary Polyurethane Derivative	225°	(107°)	-60°
GF-TFE		Glass-filled Polytetrafluorethylene	425°	(218°)	-325°	(-198°)
V-TFE		Virgin TFE	400°	(205°)	-325°	(-198°)
CTFE		Chlorotrifluoroethylene TFE	300°	148°	-325°	(-198°)
BC		Neoprene	225°	(107°)	-35°	(-37°)
NBR		Buna-N	320°	(160°)	-40°	(-40°)
Diaphragms	BC	Neoprene (Polychloroprene)	250°	(121°)	-65°	(-53°)
	EPR	Ethylene Propylene	300°	(148°)	-40°	(-40°)
	FK	Fluorosilicone	350°	(177°)	-65°	(-54°)
	FKM	Fluorocarbon Elastomer	400°	(205°)	0°	(-17°)
	NBR	Buna-N (Nitrile)	250°	(121°)	-70°	(-56°)
	FKM+TFE	Fluorocarbon Elastomer + TFE	400°	(205°)	0°	(-17°)
Static Seals	V-TFE	Virgin TFE	400°	(205°)	-325°	(-198°)
	EPR	Ethylene Propylene	300°	(148°)	-40°	(-40°)
	FK	Fluorosilicone	350°	(177°)	-65°	(-54°)
	FKM	Fluorocarbon Elastomer	400°	(205°)	-20°	(-28°)
	NBR	Buna-N	212°	(100°)	-40°	(-40°)
	SST/TFE	301/302 SST U-cup / TFE	400°	(205°)	-325°	(-198°)
Dynamic Seals	"CW" – EPR/TFE	TFE Cap Seal, EPR O-ring, GF-TFE Wiper	300°	(148°)	-40°	(-40°)
	"CW" – NBR/TFE	TFE Cap Seal, NBR O-ring, GF-TFE Wiper	212°	(100°)	-40°	(-40°)
	"CW" – FK/TFE	TFE Cap Seal, FK O-ring, GF-TFE Wiper	350°	(177°)	-40°	(-40°)
	"CW" – FKM/TFE	TFE Cap Seal, FKM O-ring, GF-TFE Wiper	400°	(205°)	-20°	(-28°)
	SST/TFE	301/302 SST U-cup / TFE	400°	(205°)	-325°	(-198°)
	ELG/TFE	Elgiloy / TFE U-cup	400°	(205°)	-325°	(-198°)

ABBREVIATIONS			
FK = Fluorosilicone	NBR = Buna-N	PTFE = Polytetrafluoroethylene	BC = Neoprene
FKM = Fluorocarbon Elastomer	V-TFE = Virgin TFE	GF-TFE = Glass-fill TFE	ELG = Elgiloy
EPR = Ethylene Propylene	CTFE = Chlorotrifluoroethylene TFE		

**TABLE 6
MAXIMUM DIAPHRAGM RATING psig (Barg) ***

NOTE: The below ratings may be further "derated" by limitations thru the Pressure Equipment Directive (97/23/EC-May '97).

Diaphragm Material	BODY SIZE 1/2"-2" (DN15-50)		BODY SIZE 2-1/2"-4" (DN65-100)
	STD DIAPHRAGM CONSTRUCTION	** OPT-81 FULL DIAPHRAGM SUPPORT	STD DIAPHRAGM CONSTRUCTION
BC, EPR	1250 (86.1)	1250 (86.1)	800 (55.1)
NBR	450 (31.0)	1250 (86.1)	300 (20.6)
FKM, FKM+TFE, FK	700 (48.2)	1250 (86.1)	550 (37.9)

* Maximum pressure setpoint of Pressure Safety Valve or Rupture disk should not exceed 1.5 times tabulated value to prevent irreversible diaphragm mechanical damage or rupture.
** Not available for DI/DI, BRZ/DI, BRZ/BRZ, CS/DI & SST/DI body/cover dome constructions.

**TABLE 7
REDUCER MAXIMUM CAPACITY WITH PLUG WIDE-OPEN**

Body Size		Full Port Max Capacity	
in	(DN)	Cv	Kv
1/2"	(15)	4.0	3.4
3/4"	(20)	8.0	6.9
1"	(25)	15	13
1-1/4"	(32)	23	20
1-1/2"	(40)	30	26
2"	(50)	60	52
2-1/2"	(65)	90	78
3"	(80)	120	104
4"	(100)	220	190

NOTE: The above Cv factors may be used for sizing of safety relief valves or rupture discs.

**TABLE 8
PRESSURE LOADING SYSTEMS
MAXIMUM CONTAINMENT PRESSURE PROCESS OR AUXILIARY GASES**

TUBE	FITTINGS	PRESSURE		TEMPERATURE	
		psig	(Barg)	°F	(°C)
CU*	BR	1400	(96.5)	-325 to +100	(-198 to +37.7)
		1140	(78.6)	200	(93.3)
		1100	(75.8)	300	(148.8)
		700	(48.2)	400	(204.4)
		3600	(248.2)	-325 to +400	(-198 to +204.4)
SST^	SST				

*1/4" O.D. X 0.030" Wall Thickness

^1/4" O.D. X 0.028" Wall Thickness

Application **Notes:**

1. For CU+BR System - if P1 pressure exceeds above limits, tubing & fittings materials as well as other system components MUST be switched over to SST materials.
2. Consult Factory for T1<0° F.
3. Use Heat Exchange "coils" when loading fluid (process, auxiliary) T1>140°F
4. Use Heat Exchange "coils" when T1<0°F
5. Other components of a given loading or piloting system may have lower limits of pressure or temperature than the tubing & fittings.

**TABLE 9
REDUCER – LOWER PISTON SPRING RANGES**

Lower Piston Spring Range psig	Application Notes
N/A	–
1–2	Pressure Loaded; P ₂ ≤ 10 psig
2–5	Pressure Loaded; P ₂ > 5 psig

- NOTES:**
1. The 1–2 psig lower piston spring should only be used with low pressure setpoints. (P_{sp} ≤ 10 psig).
 2. The 2–5 psig lower piston spring is –
 - most commonly selected,
 - recommended for P₂ > 10 psig or ΔP_{DIFF} > 10 psid,
 - recommended for GF-TFE and CTFE seats,
 - recommended for tighter shutoff; i.e. lowest inboard leakage.
 3. Lower spring material matches main metallic trim in corrosion resistance.

TABLE 10
INBOARD LEAKAGE RATINGS *
Per ANSI/FCI 70-2

Seat Material	Dynamic Seal	
	O-Ring	Dynamic Seals Except O-Ring
CTFE, GF-TFE, and V-TFE	IV	IV
BC, NBR, PolyAll	VI	IV
*Inboard leak rates are the composite leakage of the seat leakage + dynamic seal leakage, considered as a single inboard leakage value.		

TABLE 11
REDUCER RECOMMENDED VELOCITY LIMITS

Application Fluid	Valve		Valve Body Outlet		Downstream Pipe		Units
	Type	Size Range	Recommend	Max.	Recommend	Max.	
Gas	PRV	1/2"-1"	0.20	0.40	0.15	0.30	Mach #
		1-1/4"-2"	0.25	0.45	0.20	0.30	
		2-1/2"-6"	0.30	0.50	0.25	0.35	
		8"-12"	-	-	0.25	0.40	
NOTES: 1. If valve outlet exceeds recommended limits, then can use external sensing to reach maximum limits. 2. On gas service, a pilot operated prv can work with a outlet Mach = 0.75.							

TABLE 12
MAXIMUM RECOMMENDED NOISE LIMITS *

Criteria	Body Sizes		Noise Level - dBA
	in	(DN)	
Per OSHA Regs. w/noise attenuation methods incorporated.	All	All	85-95
Sch. 80 pipe, no insulation.	1/2"-2"	(15-50)	95
Std. wt. pipe, no insulation.	2-1/2"-4"	(65-100)	98
* Consult Factory for ALL applications exceeding 97 dBA noise prediction.			

Schemes To Reduce High Noise –

- Staging – using two separate throttling valves in series.
- dB Plates – using 1, 2 or 3-stage dB Plate cartridges downstream of a throttling valve.
- Paralleling – using two separate throttling valves in parallel.
- Combinations – using multiple methods of above three possibilities.

TABLE 13
RECOMMENDED INTERNAL MATERIALS
For P_{max}: Reference Individual Technical Bulletins

GASES				
Atmospheric Gases	Fluid	Tmax °F	Tmin °F	Trim
	Atmospheric Gases	Atmospheric Gases –	225°	-60°
O ₂ (GOX)		350°	-65°	M9
N ₂ (GN ₂), Air, Argon		180°	-60°	P2
		350°	-65°	P8
CO ₂ (dry)		180°	-40°	P6
CO ₂ (wet)		180°	-40°	P5
Process Gases	Process Gases –	180°	-65°	PW
	Nat. Gas (Sweet)			
	LPG (propane)	180°	-40°	PH
	Ammonia	120°	-40°	CF *
	Hydrogen Chloride (dry)	120°	-40°	SJ
	Hydrogen Bromide (dry)	120°	0°	PE
	Hydrogen Fluoride (dry)	120°	0°	PE
	Sulfur Dioxide (dry)	120°	0°	PE
* CF Consult Factory				

SUPPLEMENT for TABLE 13
CHEMICAL RESISTANCE

General Statement: Statements located within this technical bulletin concerning suitability of fluids with TFE materials are general statements, and should not be construed as recommendations. Any statements of suitability are the result of a compilation of various sources of information based on experience, tests, and published technical literature. No guarantee or warranty is in anyway implied for a given particular service or application.

Additional Reference: For an inclusive listing covering a broader range of service application fluids, reference “Handbook of Corrosion Resistant Piping”, P.A. Schweitzer, Industrial Press; or “Compass Corrosion Guide”, 2nd Edition, K.M. Pruett, Compass Publications. This publication will include information based on the following fluid variables:

1. Solution concentration
2. Pressure
3. Temperature

Inverse Sympathetic Ratio (ISR) - effect on regulator performance.

SLR-2 regulators utilize a top and bottom guide, "flow to open" trim design. The top guide also acts as a "balancing" piston to oppose the forces generated by the inlet pressure acting on the valve plug. A small residual imbalance between the piston and the valve plug helps to reduce seat leakage at high differential pressures across the seat joint. This same imbalance produces an Inverse Sympathetic Ratio, ISR effect, as the delta pressure across the seat (DP) changes. The magnitude of the ISR effect is given in Table -14.

TABLE 14		
Body Size		SLR-2
in	(DN)	
1/2", 3/4", 1"	(15,20,25)	0.03
1-1/4", 1-1/2"	(32,40)	0.04
2"	(50)	0.02
2-1/2", 3", 4"	(65,80, 100)	0.054

In a similar manner the ISR effect will produce an offset between the loading pressure, PL, and the pressure setpoint of a dome loaded regulator. For example, a 4" SLR-2 with an inlet pressure, P1 of 300 psig and an outlet pressure, P2 of 50 psig would require a loading pressure, $PL = (P1 - P2) \times ISR + P2 = (300 - 50) \times 0.054 + 50 = 63.5$ psig. In addition, if the DP changes, then a setpoint offset would be observed with a constant loading pressure.

FIGURE F1
Dynamic - Static Seals

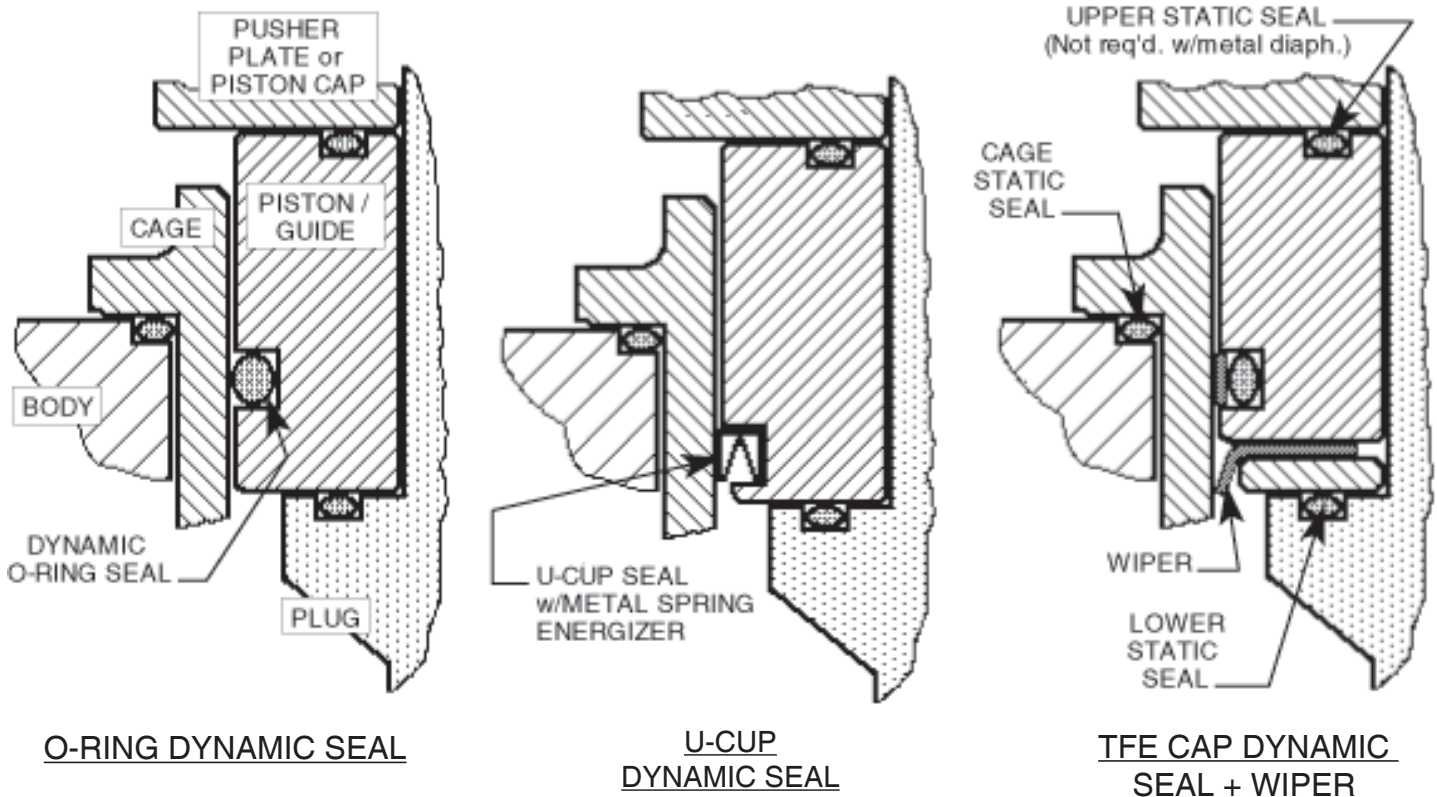
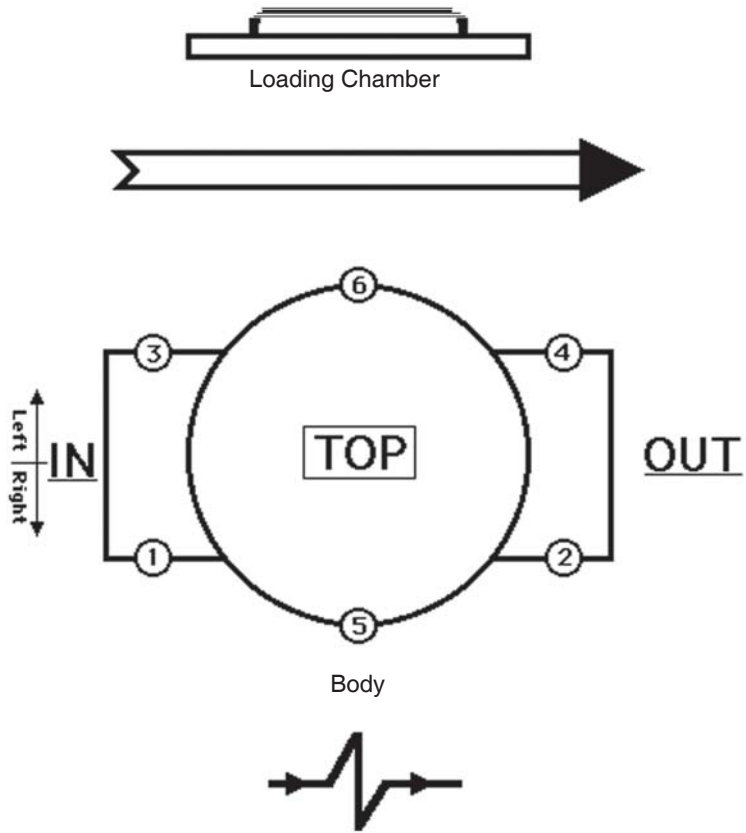

FIGURE F2
Location of BODY TAPS



Flow To Open Direction

Location	Description	Opt. No.	NPT - Size	Body Mat'l.
1 & 2	Inlet & Outlet – Right	STD	1/4"	DI, CS & SST
1, 2 & 3	Inlet & Outlet – Right	STD	1/4"	BRZ
5	External Sensing – Right	STD	1/4"	DI, BRZ, CS & SST
1, 2, 3 & 4	Inlet & Outlet – Right Inlet & Outlet – Left	85	1/4"	DI, BRZ, CS & SST
5 & 6	Double External Sensing	85	1/4"	DI, BRZ, CS & SST

DIMENSION and WEIGHTS

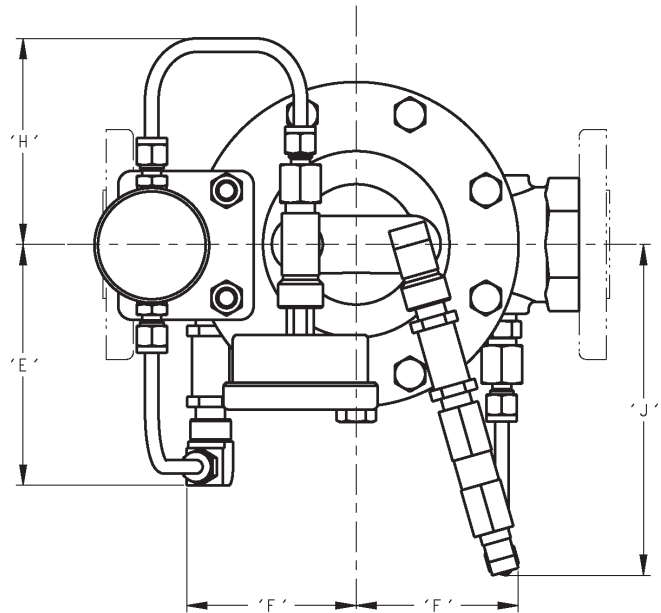
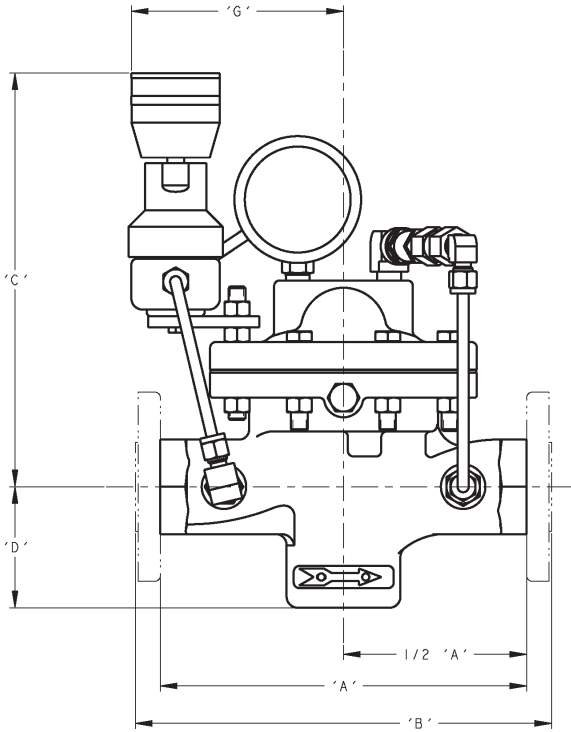

ENGLISH UNITS (in) (lbs)

METRIC UNITS (mm) (kg)

DIMEN.	END CONN.	BODY MAT'L	BODY SIZE					
			1/2", 3/4 & 1"	1-1/4" & 1-1/2"	2"	2-1/2"	3"	4"
A	NPT	DI, BRZ	6.00	9.88	9.88	-	-	-
		CS, SST	8.25	9.88	9.75	-	-	-
B	125# FF	DI	-	-	-	10.88	11.75	13.88
	250# RF	DI	-	-	-	11.50	12.50	14.50
	150# FF	BRZ **	9.63	11.50 √	11.50	10.88	11.75	13.88
	300# FF	BRZ **	9.63	11.50 √	11.50	11.50	12.15	14.50
	150# RF	CS, SST	10.75	12.38 √	10.00	10.88	11.75	13.88
	150# RF ‡	CS, SST	14.00	14.00 √	14.00	-	-	-
	300# RF	CS, SST	10.75	12.38 √	10.50	11.50	12.50	14.50
	300# RF ‡	CS, SST	14.00	14.00 √	14.00	-	-	-
	600# RF	CS, SST	10.75	12.38 √	11.25	12.25	13.25	15.50
600# RF ‡	CS, SST	14.00	14.00 √	14.00	-	-	-	
C	ALL	ALL	9.50	10.00	10.25	11.75	13.25	13.25
D	ALL	ALL	2.84	3.69	4.00	5.25	5.75	7.00
E	ALL	ALL	4.50	4.75	5.13	6.25	6.63	6.63
F	ALL	ALL	2.25	3.50	3.75	3.75	4.25	4.25
G	ALL	ALL	6.88	7.38	8.13	9.13	9.63	9.63
H	ALL	ALL	4.75	4.75	6.00	4.75	4.75	4.75
J	ALL	ALL	6.44	6.25	6.25	8.50	8.50	8.50
WEIGHT	wo/ Flanges	ALL	26	35	51	-	-	-
	w/ Flanges	ALL	31	45	64	93	158	167

END CONN.	BODY SIZE					
	DN15, DN20 & DN25	DN32 & DN40 √	DN50	DN65	DN80	DN100
NPT	152	251	251	-	-	-
	209	251	248	-	-	-
125# FF	-	-	-	276	298	352
250# RF	-	-	-	292	318	368
150# FF	246	292 √	292	276	298	352
300# FF	246	292 √	292	292	309	368
150# RF	273	314 √	254	276	298	352
150# RF ‡	356	356 √	356	-	-	-
300# RF	273	314 √	267	292	318	368
300# RF ‡	356	356 √	356	-	-	-
600# RF	273	314 √	286	311	336	394
600# RF ‡	356	356 √	356	-	-	-
ALL	241	254	260	298	337	337
ALL	72	94	102	133	146	178
ALL	114	121	130	159	168	168
ALL	57	89	95	95	108	108
ALL	175	187	207	232	245	245
ALL	121	121	152	121	121	121
ALL	164	159	159	216	216	216
wo/ Flanges	12	16	23	-	-	-
w/ Flanges	14	21	29	42	72	76

** Flanged BRZ bodies available in sizes 1", 1-1/2", 2", 2-1/2", 3", & 4" ONLY.
 √ Flange Connection not available for 1-1/4" size.
 ‡ Opt-34: Special 14" F to F Flange dimensions, CS and SST body material only.
 Consult Factory for dimensions of ISO DIN Flanged units. (PN16, PN25, PN40)

The contents of this publication are presented for informational purposes only, and while every effort has been made to ensure their accuracy, they are not to be construed as warranties or guarantees, express or implied, regarding the products or services described herein or their use or applicability. We reserve the right to modify or improve the designs or specifications of such product at any time without notice. Cashco, Inc. does not assume responsibility for the selection, use or maintenance of any product. Responsibility for proper selection, use and maintenance of any Cashco, Inc. product remains solely with the purchaser.

MODEL SLR-2 PRODUCT CODER 03/14/16

An "X" in POS 12 followed by a 5-digit control number overrides remaining selections.

L2	POS 3	POS 5	POS 6 & 7	POS 8	POS 10	POS 11	POS 12	POS 13	POS 14	POS 15	POS 16	POS 17	A
----	-------	-------	-----------	-------	--------	--------	--------	--------	--------	--------	--------	--------	---

POSITION 3 - SIZES			
Size		STD	OPT-81
in	(DN)	CODE	CODE
1/2"	(15)	4	J
3/4"	(20)	5	K
1"	(25)	6	L
1-1/4"	(32)	7	M
1-1/2"	(40)	8	N
2"	(50)	9	P
2-1/2"	(65)	A	NA
3"	(80)	B	NA
4"	(100)	C	NA

NA Not Available

POSITION 5 - BODY/COVER DOME MATERIALS			
Materials	CODE	Materials	CODE
DI/DI	1	LCC/LCC *	6
BRZ/DI	2	LCC/SST *	8
BRZ/BRZ	B	SST/DI	7
CS/DI	4	SST/CS *	9
CS/CS *	5	SST/SST *	A

* For Opt-81 Select CS, LCC or SST Loading Chamber Material except in Canada, use SST. See Position 3

POSITION 8 - Product Classification Under European "Pressure Equipment Directive"		
PRODUCT DESTINATION	HAZARD CATEGORY	CODE
Anywhere except Europe	N/A	7
European Countries * (CE Mark does not apply to DN25 and below)	Sound Engineering Practice (SEP)	S
	CE Marked Hazard Cat I or II	E
	ATEX	A

* For products to be placed in service in Europe - Ref to Directive 97/23/EC. Forward Completed "EU" Application Recorder prior to quotation. (Without Recorder-Processing of Purchase Order will be delayed). Contact Cashco for Assistance.

POSITION 10 - END CONNECTIONS / ASME								
Size	Material	Method	End Conn	CODE	End Conn	CODE	End Conn	CODE
1/2" - 2"	ALL	-	NPT	1	-	-	-	-
2-1/2" - 4"	DI	Integral	125#FF	2	250#RF	3	-	-
1", 1-1/2" - 4"	BRZ	Integral	150#FF	6	300#FF	7	-	-
1/2" - 3/4"	CS,SST	Opt-30	150#RF	4	300#RF	5	600# RF	8
1" - 4"	CS-SST	Integral *	-	-	-	-	-	-
1/2" - 2"	ALL	Opt-31	BSP	P	-	-	-	-
1/2" - 2" (14" F to F)	CS, SST	Opt-34 *	150#RF	V	300#RF	W	600#RF	Y

END CONNECTIONS FOR ISO DIN FLANGES								
DN15-25, 40, 50	Material	Method	End Conn	CODE	End Conn	CODE	End Conn	CODE
DN15-25, 40, 50	BRZ	Integral	PN40 FF - will mate with PN16, 25 and 40	J	-	-	-	-
DN65-100	-	-	PN16 FF	K	PN25 FF	L	PN40 FF	M
DN15-25, 40, 50	CS, SST	Opt-30	PN40 RF - will mate with PN16, 25 and 40	D	-	-	-	-
DN65-100	CS, SST	Integral	PN16 RF	A	PN25 RF	C	PN40 RF	G

* Flanges Not Available for 1-1/4" (DN32) size.
** 1" size w/ 600# RF CS, or SST has weld-on flanges Opt-30

POSITION 6 & 7 - DIAPHRAGM, SEAL & SEAT MATERIALS					
Trim	Seat (#)	Diaphragm	Static Seal	Dynamic Seal	CODE
17-4PH SST "P"	PA	BC	NBR	O-ring	P1
	PA / (BC)	BC	NBR	SST/TFE u-cup	P2 / (PU)
	CTFE	BC	NBR	SST/TFE u-cup	P3
	PA	EPR	EPR	O-ring	P4
	PA	NBR	NBR	O-ring	P5
	PA / (NBR)	NBR	NBR	SST/TFE u-cup	P6 / (PW)
	PA	FK	FK	SST/TFE u-cup	P7 ‡
	GF-TFE	FK	FK	SST/TFE u-cup	P8 ‡
	V-TFE	FK	FK	SST/TFE u-cup	P9 ‡
	PA	FKM	FKM	O-ring	PA
	PA	FKM	FKM	SST/TFE u-cup	PB
	GF-TFE	FKM	FKM	O-ring	PC
	GF-TFE	FKM	FKM	SST/TFE u-cup	PD
	V-TFE	FKM + TFE	SST/TFE u-cup √	SST/TFE u-cup	PE
	PA / (NBR)	NBR	NBR	TFE+NBR GFTFE CW	PH / (PY)
PA	EPR	EPR	TFE+EPR GFTFE CW	PJ	
PA	FK	FK	TFE+FK GFTFE CW	PK	
GF-TFE	FKM	FKM	TFE+FKM GFTFE CW	PL	
Monel "M"	PA	FK	FK	SST/TFE u-cup ‡‡	M7 ‡
	V-TFE	FK	FK	SST/TFE u-cup	M9 ‡
	V-TFE	FKM-TFE	SST/TFE u-cup √	SST/TFE u-cup	ME
	PA / (NBR)	NBR	NBR	TFE+NBR GFTFE CW	MH / (MY)
	PA	EPR	EPR	TFE+EPR GFTFE CW	MJ
	PA	FK	FK	TFE+FK GFTFE CW	MK
	GF-TFE	FKM	FKM	TFE+FKM GFTFE CW	ML
	PA	FK	FK	SST/TFE u-cup	S7 ‡
	V-TFE	FK	FK	SST/TFE u-cup	S9 ‡
	PA / (NBR)	NBR	NBR	TFE+NBR GFTFE CW	SH / (SY)
316L SST "S"	PA	EPR	EPR	TFE+EPR GFTFE CW	SJ
	PA	FK	FK	TFE+FK GFTFE CW	SK
	GF-TFE	FKM	FKM	TFE+FKM GFTFE CW	SL
	NBR	NBR	NBR	SST/TFE u-cup	SW
	PA	BC	V-TFE	ELG/TFE u-cup	NP ‡
	PA	NBR	NBR	ELG/TFE u-cup	NR
	PA	FKM	FKM	ELG/TFE u-cup	NS
	CTFE	NBR	V-TFE	ELG/TFE u-cup	NT ‡
	V-TFE	BC	VTFE	ELG/TFE u-cup	NV ‡
	PA	FK	FK	SST/TFE u-cup ‡‡	T7 ‡
17-4PH/ Monel/ 17-4PH "T"	V-TFE	FK	FK	SST/TFE u-cup	T9 ‡
	PA / (NBR)	NBR	NBR	TFE+NBR GFTFE CW	TH / (TY)
	PA	EPR	EPR	TFE+EPR GFTFE CW	TJ
	PA	FK	FK	TFE+FK GFTFE CW	TK
	GF-TFE	FKM	FKM	TFE+FKM GFTFE CW	TL

‡‡ For GOX service, PA seats allowed in BRZ Bodies w/ trim materials "M" or "T" only.
‡ For Low Ambient Temperatures (See TABLE 5 & -13 for Min. Temperatures).
√ Sizes 2-1/2"-4" use V-TFE static seal.
(#) BC and NBR Seat material not available for 2-1/2" size.

POSITION 11 - LOWER SPRING	
Spring Range psig	CODE
No Spring	0
2-5	3
1-2	5

POSITION 12 - SENSING CONFIGURATION (FLOW TO OPEN)	
Option	CODE
Internal	1
External	2
For Special Construction Contact Cashco for Special Code	X

POSITION 13 - NON-RELIEVING LOADER			
Material	Spring Range psig	CODE	
Alum Loader Max Inlet 500 psig NOT for use in Oxygen Service	0.5 - 30	A	
	0 - 10	C	
	1 - 60	D	
	2 - 150	E	
	3 - 200	F	
	5 - 300	G	
	5 - 400	H	
	2 - 25	J	
Brass Loader	2 - 50	K	
	2 - 100	L	
	3 - 250	M	
	5 - 500	N	
	10 - 750 *	P	
	2 - 25	R	
	2 - 50	S	
SST Loader for CS or SST Main Body Material	2 - 100	T	
	3 - 250	U	
	5 - 500	V	
	10 - 625 *	Z	
	10 - 750 *	W	
SST Loader with	CS Main Body Mat'l	W	
	CS M B Opt-81 **	Y	
	SST M B Opt-81 **	1	

* NOT available w/ DI or BRZ main body material.
** Select OPT-81 & Size in Position 3

POSITION 14 - FILTER-ORIFICE / FITTING / TUBING		W / Helix Coils *	CODE
No Filter / SST / SST (for SST Loader)	-	-	0
Brass / BR / Cu (for Alum or BRZ Loader)	Yes	-	A
	STD-No	-	B
SST / SST / SST (for SST Loader)	Yes	-	R
	STD-No	-	S
Brass / SST / SST (Alternate to Brass/ BR/ Cu above for Alum or Brass Loader)	Yes	-	G
	No	-	H

* See Application Notes on page 11 Table 8.

POSITION 15 - BODY OPTIONS		Option	CODE
No Option	-	-	0
Second "Set" of 1/4" (DN8) FNPT Pressure Taps & Plugs.	-85	-	T

POSITION 16 - CERTIFICATE OPTIONS		Option	CODE
No Option	-	-	0
NACE CONST: CS/CS, LCC/LCC, LCC/SST, SST/CS or SST/SST All Sizes (Except 1-1/4").	-40	-	J
SPECIAL CLEANING: Per Spec #S-1134. W/ properly selected mat'ls. Suitable for Oxygen Service. BRZ or SST body/cover dome material.	-55	-	M
SPECIAL CLEANING: Per Cashco Spec #S-1542.	-56	-	N

POSITION 17 - PAINT OPTIONS		Option	CODE
No Option	-	-	0
Epoxy Painted Per Cashco Spec #S-1547.	-95	-	W
Epoxy Painted Per Cashco Spec #S-1687 OFFSHORE Applic.	-95OS	-	Y

Cashco, Inc.
P.O. Box 6
Ellsworth, KS 67439-0006
PH (785) 472-4461
Fax. # (785) 472-3539
www.cashco.com
email: sales@cashco.com
Printed in U.S.A. SLR-2-TB

Cashco GmbH
Handwerkerstrasse 15
15366 Hoppegarten, Germany
PH +49 3342 30968 0
Fax. No. +49 3342 30968 29
www.cashco.com
email: germany@cashco.com

Cashco do Brasil, Ltda.
Al.Venus, 340
Indaiatuba - Sao Paulo, Brazil
PH +55 11 99677 7177
Fax. No.
www.cashco.com
email: brazil@cashco.com