



**MODEL PGR-1**

## APPLICATIONS

Model PGR-1 is high performance, pressure loaded diaphragm-type, flow-to-open pressure reducing regulator. Design includes an internal pressure balancing piston-cylinder that provides high flow capacity. The internal trim design allows the same basic unit to cover a broad range of pressure settings. Performance meets or exceeds that of competitive pressure loaded or pilot-operated designs. The PGR-1 regulator is applied primarily in clean natural gaseous service and fuel gas - sweet or sour.

## CAUTION

**In the event of diaphragm failure, the process fluid will vent to atmosphere.** Use FNPT taps located on spring chambers of the pilot and stabilizer for remote venting. Primarily used when handling hazardous or flammable fluids.

## MODEL PGR-1

### PILOT OPERATED PRESSURE REDUCING REGULATOR PRESSURE LOADED DIAPHRAGM: 1" – 4" (DN25 – 100)

## FEATURES

- Versatile:** Four basic materials with multiple trim material combinations to select from.
- Tight Shutoff:** Multiple composition materials provide Class IV and Class VI inboard leakage rates. Designed as a soft-seated valve.
- Capacity:** Highest in the industry. Allows smaller body sizes than competitors in majority of applications.
- Drop:** Highly accurate outlet pressure control, due to absence of range spring in main valve design, provides almost zero "droop effect".
- Trim Design:** FTO - pressure balanced trim results in unmatched sensitivity and stability. Internals are cage-contained within easily removable quick change trim.
- Heavy-Duty Guiding:** Both top and bottom guided to maintain stability and increased diaphragm life.
- Failure Position:** Fails closed on loss of loading pressure. Fails open on loss of  $P_1$  or  $P_2$  pressures with loading pressure yet applied.
- Remote Venting:** Spring Chambers on the pilot and the stabilizer include FNPT connection for remote venting of hazardous or explosive gaseous service.

## STANDARD / GENERAL SPECIFICATIONS

### Body / Cover Dome Materials

DI/DI, CS/CS, SST/SST  
 DI = Ductile Iron   CS = Carbon Steel  
 SST = Stainless Steel

### Body Sizes

1", 1-1/2", 2", 3", 4" NPS (DN25, 40, 50, 80, 100)

### End Connections

Female NPT (screwed) 1", 1-1/2, & 2" sizes only.  
ASME Flanged: 125#, 250# 3" & 4" sizes only.  
 - 150#, 300#, 600# all sizes.

### Max. Useable Cv

See Table DAG-6 for Wide Open Cv Limits.  
**METRIC CONVERSION FACTOR:  $C_v / 1.16 = k_v$**

Body Size		Cv	Body Size		Cv
in	(DN)		in	(DN)	
1"	(25)	13.5	3"	(80)	108
1-1/2"	(40)	27	4"	(100)	198
2"	(50)	54			

### Inlet Pressure Range

Operating: 10–400 psig (0.68 – 27.6 Barg).  
 See Tables DAG-1A thru -1F for design P vs. T limits.  
**NOTE:** Maximum allowable inlet pressure of the Pilot in the loading system is 250 psig. (17.2 barg).

### Outlet Pressure Range

2.0" WC – 200 psig (13.8 Barg)

### Max Pressure Drop

Spring Range	Max Drop (psig)
2" - 41" wc	50
1 - 10 psig	200
7 - 200 psig	393

For applications that exceed max drop, install a pressure regulator upstream to reduce the inlet pressure of the PGR-1.

### Min Pressure Drop

5.0 psid (.34 Bard)

### Temperature Range

-70° to +250°F (-57° to +121° C)

Limited by body/cover dome/diaphragm material combinations, and by elastomeric seat, static seal, dynamic seal – materials. See Table 2, Tables DAG-1A through -1F and Table DAG-5.

### Inboard Leakage Rates

See Table DAG-10

### Optional Constructions

Opt-21: Coalescing Filter    Opt-85: Extra Set Pressure  
Opt-25S: SST vent screen            Taps  
Opt-30: Flanged End Conns.   Opt-86: System Supply  
Opt-40: NACE Constr.                    Gauge  
Opt-55: Oxygen Cleaned    Opt-95OS: Epoxy Paint  
Opt-56: Special Cleaned

### Pilot Body / Spring Chamber Materials

DI/DI, LCC/LCC, SST/SST

### Pilot Body Size / End Connections

1/4" - NPT (DN6)

**Stabilizing Regulator** - SST body, 1/4" size, NPT connections, SST spring chamber with 1/8" FNPT vent connection, SST trim, Composition seat and diaphragm - (Buna-N for Non-NACE service; EPR for NACE service.) (FKM and Expand PTFE for Oxygen Service.)

### Tubing & Fittings

Brass fittings with copper tubing or SST fittings with SST tubing. **External sensing is standard:** end user to connect tubing from sensing port on pilot to location in downstream piping. **Self contained sensing is optional:** factory supplied tubing from sensing port on pilot to outlet of the main regulator.

### ABBREVIATIONS

BC = Neoprene	NBR = Buna-N	V-TFE = Virgin TFE	EPDM = Ethylene Propylene
---------------	--------------	--------------------	---------------------------

## MATERIAL SPECIFICATIONS

### Body

DI – ASTM A395  
CS – ASTM A216, Grade WCB.  
Alternate – ASTM A352 Grade LCC  
SST – ASTM A351, Grade CF3M.  
 See DAG-1A through DAG-1F for material specs.

### Cover Dome

DI – ASTM A395  
CS – ASTM A216, Grade WCB.  
Alternate – ASTM A352 Grade LCC  
SST – ASTM A351, Grade CF3M

### Metallic Trim

Plug, Cage, Piston: 316L SST. See Table 1.

### Diaphragm \*

Elastomeric – BC, NBR, EPDM, FK, FKM, 3-Ply

### Seat \*

BC, NBR, V-TFE

### Static Seals (See Fig. DAG-F1) \*

V-TFE

### Dynamic Seals (See Fig. DAG-F1) \*

Type OR - BC, NBR, EPDM, FKM o-ring seal.  
Type UC– V-TFE u-cup seal w/ Elgiloy energizer  
 V-TFE u-cup seal w/ 316L SST energizer

### Painting

Standard: All non-corrosion resistant portions to be painted with corrosion resistant epoxy paint per Cashco Spec #S-1606.

Alternate: See Opt-95OS.

\* See Product Coder for possible Trim combinations.  
 † Monel™, is registered trade name:  
 Monel™ is a mark owned by International Nickel Co.

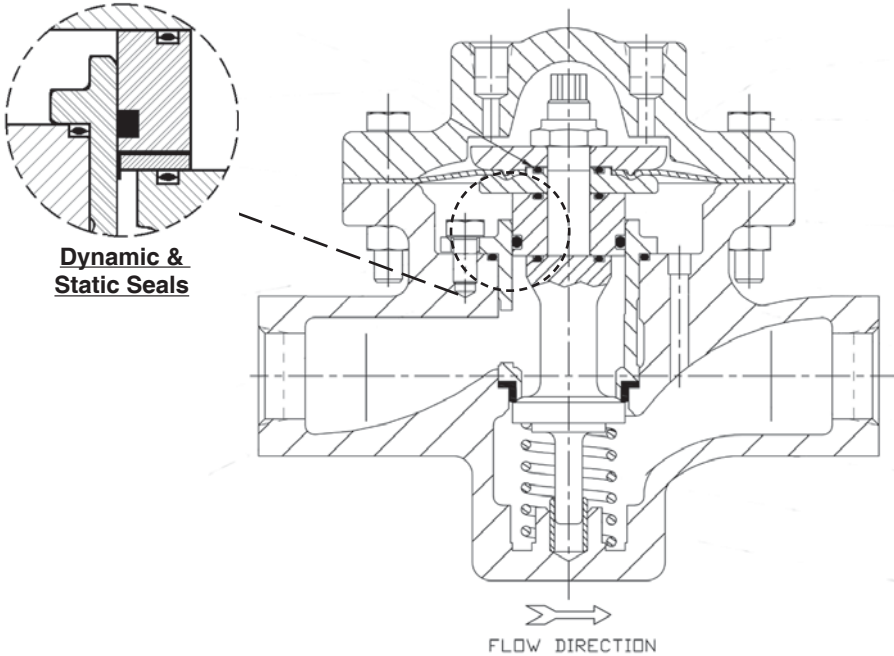

Model PGR-1 Main Body Assembly

## OPTION SPECIFICATIONS

**OPT-21:** **COALESCING FILTER.** Coalescing filter element removes moisture. Standard construction - filter element removes particulate only.

**OPT-25S:** **RAIN PROOF BUG VENTS.** SST material. Size - 1/4" NPT for pilot spring chamber, 1/8" NPT for stabilizer spring chamber. Do not use in applications where gaseous service is hazardous or explosive.

**OPT-30:** **FLANGED CONNECTIONS.** 1"(DN25) body size with ASME 600# RF flanges. Flange of same general chemistry as body.

**NOTES:** 1. The body P vs. T ratings are the limiting variables for flanged end conns, unless further restricted by ASME B16.5 or the maximum ratings as established per product design requirements.

**OPT-40:** **NACE CONSTRUCTION.** Internal wetted portions meet NACE Std. MR0175 for application in sour gas/crude service. Exterior of unit to not be directly buried, insulated, or otherwise denied direct atmospheric exposure. CS/CS, LCC/LCC or SST/SST body/cover dome materials only. 316L SST trim material only. ELG/TFE U-cup dynamic seals. Available in all end connections. The lower spring is constructed of Inconel†. SST tubing and fittings.

**OPT-55:** **SPECIAL CLEANING - GOX.** SST body materials only. Cleaning, assembly and packaging per Cashco Spec #S-1134, making unit suitable for Oxygen Service. **NOTE: Design Pressure Rating shall not exceed 375 psig (25.8 Barg) when body material is SST and process medium is oxygen.**

**OPT-56:** **SPECIAL CLEANING.** Cleaning per Cashco Spec. No. S-1542 for all body/cover dome materials. Higher cleaning level than std. commercial cleaning. NOT suitable for Oxygen Service.

**OPT-85:** **PRESSURE TAPS.** Provides second set of inlet and outlet 1/4" (DN8) - FNPT taps with plugs (same basic material as body) on backside of body. Includes second external sensing port tap. See page 10 for details on tap location for both STD. and Opt -85.

**OPT-86:** **SYSTEM SUPPLY GAUGE.** Glycerin filled pressure gauge. SST case, bourdon tube, socket, and movement. 2 1/2" (64 mm) dial size. Service application temperature range of 30 to +160°F (-1 to +71°C) maximum. Rear case 1/4" (DN8) NPT male connection.

**OPT-95OS:** **EPOXY PAINT.** Special epoxy painting of all non-corrosion resistant external surfaces per Cashco Spec #S-1687. Utilized in OFFSHORE atmospheric conditions.

### TECHNICAL SPECIFICATIONS

TABLE 1		
PART	TRIM MATERIALS	
Plug	316L SST	
Guide Bearing	2"-41"WC range	1-200 psig range
	Aluminum	316L SST
Cage	316L SST	
Body Bushing	Monel †	
† See Page 3 for registered trade name information.		

TABLE 2								
SEAT, DIAPHRAGM & SEAL TRIM COMBINATIONS							Temp. Rg.	
Set Point Range	Main Valve		Main Valve		Pilot		°F	°C
	Seat	Diaphragm	Static Seal	Dynamic Seal	Ball	Diaphragm		
2"-41"WC	BC	BC	V-TFE	BC O-ring	BC	BC	-35 - +212	-37 - +100
	NBR	NBR	V-TFE	NBR O-ring	NBR	NBR *	-20 - +200	-28 - +93
	NBR	NBR	V-TFE	NBR O-ring	440C SST	NBR *	-40 - +250	-40 - +121
	BC	EPDM	V-TFE	EPDM O-ring	EPDM	EPDM **	-40 - +200	-40 - +93
13"-41" WC	BC	BC	V-TFE	ELG/TFE U-cup	BC	BC	-40 - +212	-40 - +100
	NBR	NBR	V-TFE	ELG/TFE U-cup	NBR	NBR *	-20 - +200	-28 - +93
	V-TFE	NBR	V-TFE	ELG/TFE U-cup	NBR	NBR *	-20 - +250	-28 - +121
1-200 psig	BC	BC	V-TFE	BC O-ring	BC ***	BC	-35 - +212	-37 - +100
	NBR	NBR	V-TFE	NBR O-ring	NBR ***	NBR *	-20 - +200	-28 - +93
	BC	BC	V-TFE	ELG/TFE U-cup	BC ***	BC	-40 - +212	-40 - +100
	NBR	NBR	V-TFE	ELG/TFE U-cup	NBR ***	NBR *	-20 - +200	-28 - +93
	NBR	NBR	V-TFE	ELG/TFE U-cup	440C SST	NBR *	-40 - +250	-40 - +121
	V-TFE	NBR	V-TFE	NBR O-ring	440C SST	NBR *	-65 - +250	-54 - +121
	V-TFE	NBR	V-TFE	ELG/TFE U-cup	440C SST	NBR *	-70 - +250	-57 - +121
	BC	EPDM	V-TFE	EPDM O-ring	EPDM ***	EPDM **	-40 - +200	-40 - +93
1-200 psig Oxygen Ser. Trims	V-TFE	FKM	V-TFE	FKM O-ring	316 SST	FKM *	0 - +400	-17 - +205
	V-TFE	FKM	V-TFE	SST/TFE U-cup	316 SST	FKM *	0 - +400	-17 - +205
	V-TFE	TFE/FKM/TFE	V-TFE	SST/TFE U-cup	316 SST	Expand PTFE *	+100 - +400	+38 - +205
	V-TFE	FK	V-TFE	SST/TFE U-cup	316 SST	Expand PTFE ***	-65 - +350	-54 - +177

\* Not recommended for NACE Applications.  
 \*\* Not recommended for use in Natural Gas Applications.  
 \*\*\* For spring range 90 - 200 psig ball material is 316 SST.

**DAG TECHNICAL APPENDIX INDEX**

<b>TABLE</b>	<b>TITLE</b>	<b>PAGE</b>
DAG-1A	DI – Press vs Temp vs End Conn Ratings	5
DAG-1C	CS – Press vs Temp vs End Conn Ratings - Design Inlet	6
DAG-1D	Design Outlet	6
DAG-1E	SST – Press vs Temp vs End Conn Ratings – Design Inlet	7
DAG-1F	Design Outlet	7
DAG-5	Temperature Limits – Elastomer Mat'ls.	8
DAG-6	Reducer Max Capacity - Plug Wide Open	8
DAG-10	Inboard Leakage Ratings	8
DAG-11	Reducer Recommended Velocity Limits	8
DAG-13	Max Recommended Noise Limits	9
DAG-14	Supplement - Chemical Resistance	9
<b>FIGURE</b>		
DAG-F1	Dynamic/Static Seals	10
DAG-F2	Body/Spring Chamber Taps	10

**TABLE DAG-1A**  
**DI – DUCTILE IRON**  
**BODY / TOPWORKS MATERIAL SPECIFICATIONS**  
**DESIGN PRESSURE vs. TEMPERATURE vs. END CONNECTION RATINGS**  
 (To ASME B16.1 for Flanged and B16.4 for NPT Connections per Cast Iron Rating)  
 See NOTES 1 & 2

Material Specifications (Body / Topworks)		End Connection – Inlet & Outlet					
		Temperature °F	Working Pressure – psig				
Description (Abbr.)	ASTM No.		End Connection – Pressure Class				
		NPT	125# FF	250# RF			
DI/DI (Note 1)	A395/ A395	-20° to +150°	400	200	500		
		200°	370	190	460		
		225°	355	180	440		
		250°	340	175	415		
		300°	310	165	375		
		350°	300	150	335		
		400°	250	140	290		
		406°	250	140	290		
			400 WOG, 250 S	225 WOG, 125 S	400 WOG, 250 S		
				Working Pressure – Barg			
				End Connection – Pressure Class			
				NPT	125# FF	250# RF	
				-29° to +65°	27.6	13.8	34.5
				107	24.5	12.5	30.2
				120°	23.4	12.1	28.7
		150°	21.2	11.2	25.7		
		177°	19.2	10.6	23.8		
		204°	17.5	9.6	20.3		

**NOTE 1:** These pressure ratings may be further derated by limitations thru the Pressure Equipment Directive (97/23/EC-May '97).

**NOTE 2:** The maximum inlet pressure of the Pilot in the loading system is 250 psig (17.2 Barg)

**Body Material Specifications**

**Cast Steel** A216 Gr. WCB or Steel Weldment A216 Gr. WCB w/ forged flanges A105

**Alternate Material:** Cast Steel A352 Gr. LCC or Steel Weldment A352 Gr. LCC w/ forged flanges A350 Gr. LF6 Class 2

**Topworks Material Specifications**

**Cast Steel** A216 Gr. WCB

**Alternate Material:** Cast Steel A352 Gr. LCC

**DESIGN PRESSURE vs. TEMPERATURE vs. END CONNECTION RATINGS**

(Per ASME B16.5 and B16.34) See NOTES 1 & 2

<b>TABLE DAG-1C</b>			
<b>DESIGN <u>INLET</u> PRESSURE FOR PGR-1</b>			
<b>in PSIG (BARG)</b>			
<b>CONSTRUCTION</b>	<b>END CONNECTIONS</b>		
<b>DESIGN TEMP. RANGE: Deg F (Deg C) **</b>	<b>NPT, 600#</b>	<b>150#</b>	<b>300#</b>
-20 to +100 (-29 to +38)	1480 (102.1)	285 (19.6)	740 (51.1)
-20 to +200 (-29 to +93)	1360 (94.2)	260 (17.9)	680 (47.1)
-20 to +300 (-29 to +149)	1310 (90.3)	230 (15.8)	655 (45.1)
-20 to +400 (-29 to +204)	1265 (87.3)	200 (13.7)	635 (43.6)
** Alternate Mat'l: ASTM 352 Gr. LCC Minimum Temperature -50 °F (-46 °C).			

<b>TABLE DAG-1D</b>			
<b>DESIGN <u>OUTLET</u> PRESSURE FOR PGR-1</b>			
<b>in PSIG (BARG)</b>			
<b>CONSTRUCTION</b>	<b>END CONNECTIONS</b>		
<b>DESIGN TEMP. RANGE: Deg F (Deg C) **</b>	<b>NPT, 600#</b>	<b>150#</b>	<b>300#</b>
-20 to +100 (-29 to +38)	750 (51.7)	285 (19.6)	740 (51.1)
-20 to +200 (-29 to +93)	680 (47.1)	260 (17.9)	680 (47.1)
-20 to +300 (-29 to +149)	655 (45.1)	230 (15.8)	655 (45.1)
-20 to +400 (-29 to +204)	635 (43.6)	200 (13.7)	635 (43.8)
** Alternate Mat'l: ASTM 352 Gr. LCC Minimum Temperature -50 °F (-46 °C).			

**NOTE 1:** These pressure ratings may be further derated by limitations thru the Pressure Equipment Directive (97/23/EC-May '97).

**NOTE 2:** The maximum inlet pressure of the Pilot in the loading system is 250 psig (17.2 Barg)

**Body Material Specifications**

**Cast Stainless Steel** A351 Gr.CF3M or Stainless Steel Weldment A315 Gr. CF3M w/ forged flanges A182 Gr. F 316L

**Topworks Material Specifications**

**Cast Stainless Steel** A351 Gr.CF3M

**DESIGN PRESSURE vs. TEMPERATURE vs END CONNECTION RATINGS**

(Per ASME B16.5 and B16.34) See NOTES 1 & 2

<b>TABLE DAG-1E</b>			
<b>DESIGN INLET PRESSURE FOR PGR-1</b>			
<b>in PSIG (BARG)</b>			
<b>CONSTRUCTION</b>	<b>END CONNECTIONS</b>		
<b>DESIGN TEMP. RANGE: Deg F (Deg C)</b>	<b>NPT, 600#</b>	<b>150#</b>	<b>300#</b>
-425 to +100 (-254 to +38)	1440 (99.3)	275 (19.0)	720 (49.6)
-20 to +200 (-29 to +93)	1240 (86.1)	235 (16.5)	620 (43.0)
-20 to +300 (-29 to +149)	1120 (77.1)	215 (14.8)	560 (38.6)
-20 to +400 (-29 to +204)	1025 (70.9)	195 (13.6)	515 (35.5)

<b>TABLE DAG-1F</b>			
<b>DESIGN OUTLET PRESSURE FOR PGR-1</b>			
<b>in PSIG (BARG)</b>			
<b>CONSTRUCTION</b>	<b>END CONNECTIONS</b>		
<b>DESIGN TEMP. RANGE: Deg F (Deg C)</b>	<b>NPT, 600#</b>	<b>150#</b>	<b>300#</b>
-425 to +100 (-254 to +38)	625 (43.0)	275 (19.0)	625 (43.0)
-20 to +200 (-29 to +93)	620 (42.3)	235 (16.5)	620 (42.3)
-20 to +300 (-29 to +149)	560 (38.6)	215 (14.8)	560 (38.6)
-20 to +400 (-29 to +204)	515 (35.5)	195 (13.6)	515 (35.5)

**NOTE 1:** These pressure ratings may be further derated by limitations thru the Pressure Equipment Directive (97/23/EC-May '97).

**NOTE 2:** The maximum inlet pressure of the Pilot in the loading system is 250 psig (17.2 Barg)



**TABLE DAG-5  
TEMPERATURE LIMITS  
FOR ELASTOMERIC MATERIALS**

Elastomer			T Maximum		T Minimum	
Seats	ID	Description	°F	(°C)	°F	(°C)
	BC	Neoprene	225	(107)	-35	(-37)
	NBR	Buna-N	320	(160)	-40	(-40)
	V-TFE	Virgin TFE	400	(205)	-325	(-198)
Diaphragms	BC	Neoprene (Polychloroprene)	250	(121)	-65	(-53)
	NBR	Buna-N (Nitrile)	250	(121)	-70	(-56)
	EPDM	Ethylene Propylene	300	(148)	-40	(-40)
	FK	Fluorosilicone	350	(177)	-65	(-54)
	FKM	Fluorocarbon Elastomer	400	(205)	0	(-17)
	PTFE	Expanded PTFE	400	(205)	-325	(-198)
	3-Ply	3-Ply (TFE/FKM/TFE)	400	(205)	0	(-17)
Static Seals	V-TFE	Virgin TFE	400	(205)	-325	(-198)
Dynamic Seals	BC	Neoprene O-ring	212	(100)	-35	(-37)
	NBR	NBR O-ring	212	(100)	-40	(-40)
	EPDM	EPDM O-ring	300	(148)	-40	(-40)
	ELG/TFE	Elgiloy / TFE U-cup	400	(205)	-325	(-198)
	FKM	FKM O-ring	400	(205)	-20	(-28)
	SST/TFE	SST / TFE U-cup	400	(205)	-325	(-198)
Ball	BC	NEOP	212	(100)	-40	(-40)
	NBR	BUNA-N	200	(93)	-20	(-28)
	EPDM	EPDM	300	(148)	-55	(-48)

**TABLE DAG-6  
REDUCER MAXIMUM CAPACITY  
WITH PLUG WIDE-OPEN**

Body Size		Full Port Max Capacity	
in	(DN)	Cv	Kv
1"	(25)	15	13
1-1/2"	(40)	30	26
2"	(50)	60	52
3"	(80)	120	104
4"	(100)	220	190

**NOTE:** The above Cv factors may be used for sizing of safety relief valves or rupture discs.

**TABLE DAG-10  
INBOARD LEAKAGE RATINGS \*  
Per ANSI/FCI 70-2**

Seat Material	Dynamic Seal	
	O-Ring	Dynamic Seals Except O-Ring
BC, NBR	VI	IV
V-TFE	IV	IV

\*Inboard leak rates are the composite leakage of the seat leakage + dynamic seal leakage, considered as a single inboard leakage value.

**TABLE DAG-11  
REDUCER RECOMMENDED VELOCITY LIMITS**

Application Fluid	Valve		Valve Body Outlet		Downstream Pipe		Units
	Type	Size Range	Recommend	Max.	Recommend	Max.	

**NOTE:** On gas service, a pilot operated PRV can work with a Regulator body outlet Mach = 0.75.



**TABLE DAG 13  
MAXIMUM RECOMMENDED NOISE LIMITS \***

Criteria	Body Sizes		Noise Level - dBA
	in	(DN)	
Per OSHA Regs. w/noise attenuation methods incorporated.	All	All	85-95
Sch. 80 pipe, no insulation.	1" - 2"	(25-50)	95
Std. wt. pipe, no insulation.	3" - 4"	(80-100)	98

\* Consult Factory for ALL applications exceeding 97 dBA noise prediction.

**Schemes To Reduce High Noise –**

- Staging – using two separate throttling valves in series.
- dB Plates – using 1, 2 or 3-stage dB Plate cartridges downstream of a throttling valve.
- Paralleling – using two separate throttling valves in parallel.
- Combinations – using multiple methods of above three possibilities.

**DAG-14 SUPPLEMENT  
CHEMICAL RESISTANCE**

**General Statement:** Statements located within this technical bulletin concerning suitability of fluids with TFE materials are general statements, and should not be construed as recommendations. Any statements of suitability are the result of a compilation of various sources of information based on experience, tests, and published technical literature. No guarantee or warranty is in anyway implied for a given particular service or application.

**Additional Reference:** For an inclusive listing covering a broader range of service application fluids, reference “Handbook of Corrosion Resistant Piping”, P.A. Schweitzer, Industrial Press, 1969; or “Compass Corrosion Guide”, 2nd Edition, K.M. Pruett, Compass Publications, 1983. This publication will include information based on the following fluid variables:

1. Solution concentration
2. Pressure
3. Temperature

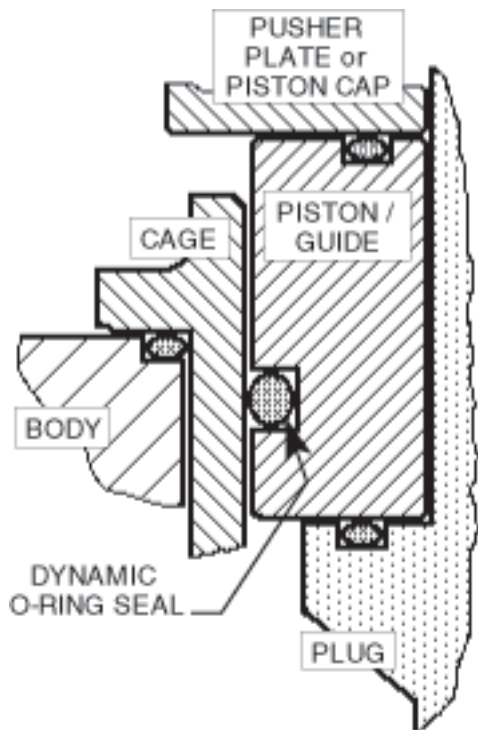

**O-RING DYNAMIC SEAL**

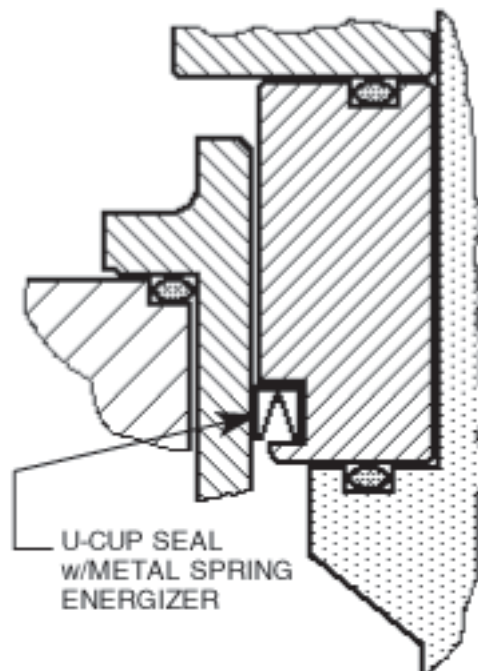

**U-CUP DYNAMIC SEAL**

**FIGURE DAG-F2  
Location of BODY TAPS**

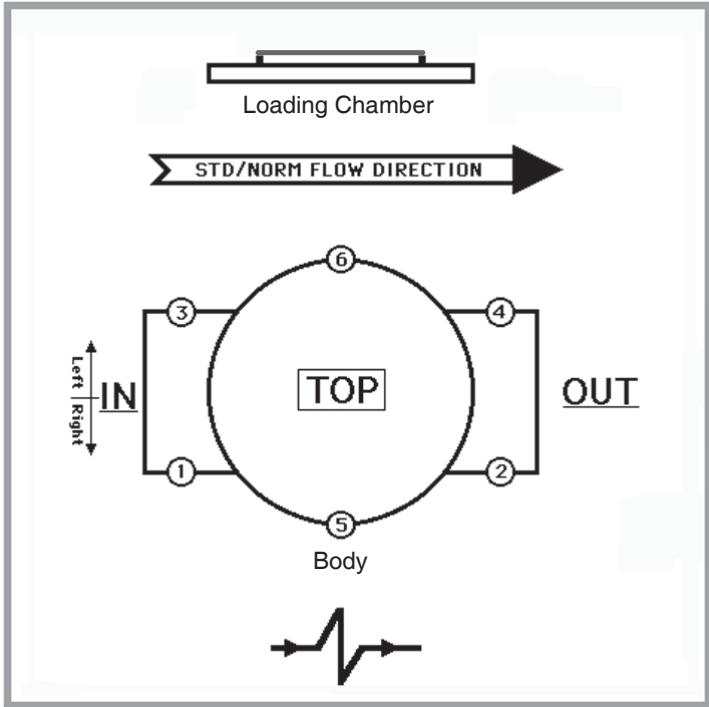

Location	Description	Opt. No.	NPT - Size
1 & 2	Inlet & Outlet – Right	STD	1/4"
5	External Sensing – Right	STD	1/4"
1, 2, 3 & 4	Inlet & Outlet – Right Inlet & Outlet – Left	85	1/4"
5 & 6	Double External Sensing	85	1/4"

**DIMENSION and WEIGHTS**

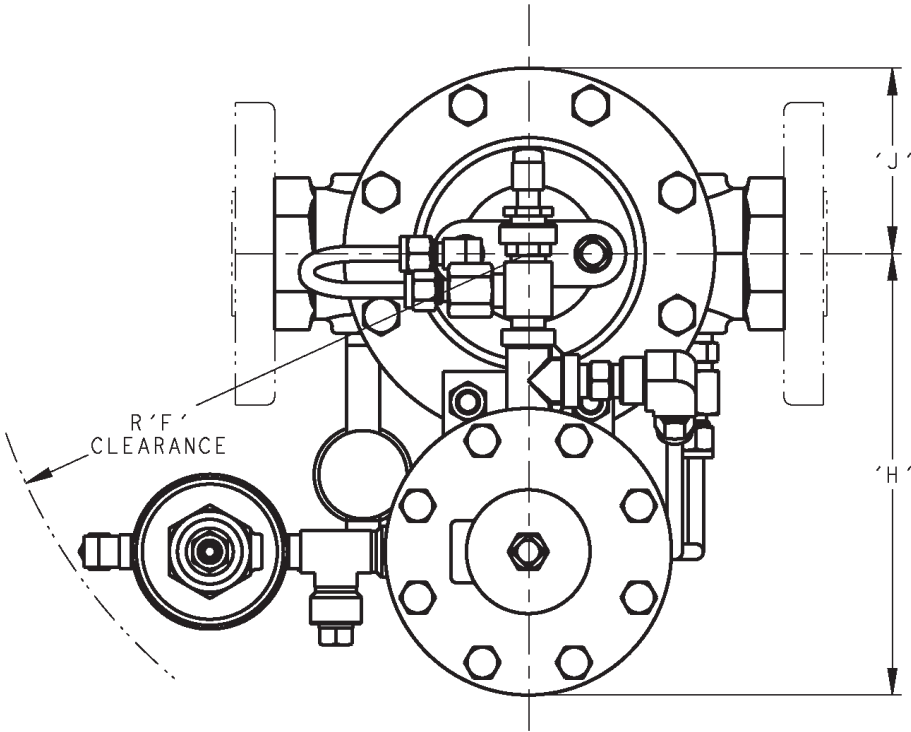

## DIMENSION and WEIGHTS

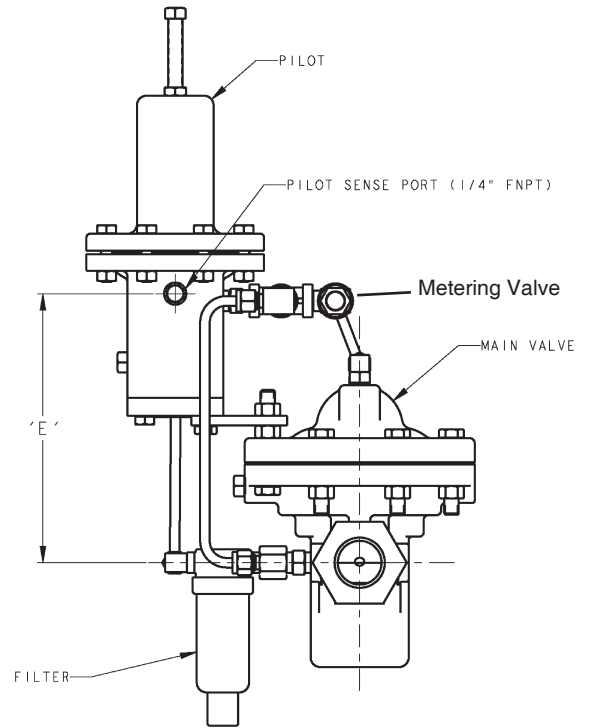
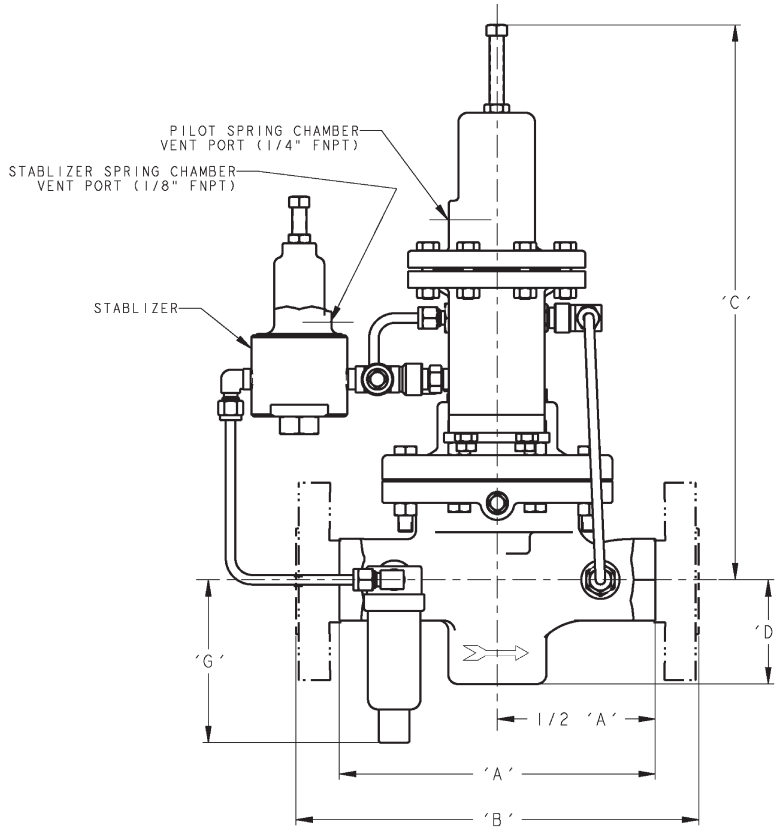

### ENGLISH UNITS (in) (lbs)

DIMEN.	END CONN.	BODY MAT'L	BODY SIZE				
			1"	1-1/2"	2"	3"	4"
A	NPT	DI	6.00	9.88	9.88	-	-
		CS, SST	8.25	9.88	9.75	-	-
B	125# FF	DI	-	-	-	11.75	13.88
	250# RF	DI	-	-	-	12.50	14.50
	150# RF	CS, SST	10.75	12.38	10.00	11.75	13.88
	300# RF	CS, SST	10.75	12.38	10.50	12.50	14.50
	600# RF	CS, SST	10.75	12.38	11.25	13.25	15.50
C	ALL	ALL	16.50	16.75	17.00	19.50	19.50
D	ALL	ALL	2.84	3.69	4.00	5.75	7.00
E	ALL	ALL	7.00	7.50	8.00	10.50	10.50
F	ALL	ALL	10.00	10.00	11.00	11.00	11.00
G	ALL	ALL	4.25	4.25	4.25	-	-
H	ALL	ALL	4.75	5.25	8.25	9.50	9.50
J	ALL	ALL	3.00	3.50	4.00	5.50	5.50
WEIGHT	wo/ Flanges	ALL	46	50	71	-	-
	w/ Flanges	ALL	51	55	84	178	187

### METRIC UNITS (mm) (kg)

DIMEN.	END CONN.	BODY MAT'L	BODY SIZE				
			DN25	DN40	DN50	DN80	DN100
A	NPT	DI	152	251	251	-	-
		CS, SST	209	251	248	-	-
B	125# FF	DI	-	-	-	298	352
	250# RF	DI	-	-	-	318	368
	150# RF	CS, SST	273	314	254	298	352
	300# RF	CS, SST	273	314	267	318	368
	600# RF	CS, SST	273	314	286	336	394
C	ALL	ALL	419	425	432	495	495
D	ALL	ALL	72	94	102	146	178
E	ALL	ALL	178	191	203	267	267
F	ALL	ALL	254	254	279	279	279
G	ALL	ALL	108	108	108	-	-
H	ALL	ALL	122	132	210	241	241
J	ALL	ALL	76	89	101	140	140
WEIGHT	wo/ Flanges	ALL	21	22	32	-	-
	w/ Flanges	ALL	23	25	38	81	85

The contents of this publication are presented for informational purposes only, and while every effort has been made to ensure their accuracy, they are not to be construed as warranties or guarantees, express or implied, regarding the products or services described herein or their use or applicability. We reserve the right to modify or improve the designs or specifications of such product at any time without notice.

Cashco, Inc. does not assume responsibility for the selection, use or maintenance of any product. Responsibility for proper selection, use and maintenance of any Cashco, Inc. product remains solely with the purchaser.

# MODEL PGR-1 PRODUCT CODER 03/14/16

An "X" in POS 12 followed by a 5-digit control number overrides remaining selections.



POSITION 3 - SIZES		
Size	STD	
in	(DN)	CODE
1"	(25)	6
1-1/2"	(40)	8
2"	(50)	9
3"	(80)	B
4"	(100)	C

POSITION 5 - BODY/COVER DOME MATERIALS			
Materials	CODE	Materials	CODE
DI/DI	1	LCC/LCC	6
CS/CS	5	SST/SST	A

POSITION 6 & 7 - SEAT & DIAPHRAGM MATERIALS							
Set Point Range	Main Valve		Main Valve		Pilot		CODE
	Seat	Diaphragm	Static Seal	Dynamic Seal	Ball	Diaphragm	
2"-41"WC	BC	BC	V-TFE	BC O-ring	BC	BC	S1 *
	NBR	NBR	V-TFE	NBR O-ring	NBR	NBR	S2
	NBR	NBR	V-TFE	NBR O-ring	440C SST	NBR	S3
	BC	EPDM	V-TFE	EPDM O-ring	EPDM	EPDM	S4 **
13-41"WC	BC	BC	V-TFE	ELG/TFE U-cup	BC	BC	SJ *
	NBR	NBR	V-TFE	ELG/TFE U-cup	NBR	NBR	SK
	V-TFE	NBR	V-TFE	ELG/TFE U-cup	NBR	NBR	SL
1-200 psig	BC	BC	V-TFE	BC O-ring	BC ***	BC	SA *
	NBR	NBR	V-TFE	NBR O-ring	NBR ***	NBR	SB
	BC	BC	V-TFE	ELG/TFE U-cup	BC ***	BC	SC *
	NBR	NBR	V-TFE	ELG/TFE U-cup	NBR ***	NBR	SD
	NBR	NBR	V-TFE	ELG/TFE U-cup	440C SST	NBR	SE
	V-TFE	NBR	V-TFE	NBR O-ring	440C SST	NBR	SF
	V-TFE	NBR	V-TFE	ELG/TFE U-cup	440C SST	NBR	SG
	BC	EPDM	V-TFE	EPDM O-ring	EPDM ***	EPDM	SH **
1-200 psig Oxygen Ser. Trims	V-TFE	FKM	V-TFE	FKM O-ring	316 SST	FKM	SM
	V-TFE	TFE/FKM/TFE	V-TFE	SST/TFE U-cup	316 SST	Expand PTFE	SP
	V-TFE	FK	V-TFE	SST/TFE U-cup	316 SST	Expand PTFE	SR **

POSITION 8 - Product Classification Under European "Pressure Equipment Directive"		
PRODUCT DESTINATION	HAZARD CATEGORY	CODE
Anywhere except Europe	N/A	7
European Countries * (CE Mark does not apply to DN25 and below)	Sound Engineering Practice (SEP)	S
	CE Marked Hazard Cat I or II	E

\* For products to be placed in service in Europe - Ref to Directive 97/23/EC. Forward Completed "EU" Application Recorder prior to quotation. (Without Recorder- Processing of Purchase Order will be delayed). Contact Cashco for Assistance.

POSITION 10 - END CONNECTIONS / ASME							
Size	Material	End Conn	CODE	End Conn	CODE	End Conn	CODE
1" - 2"	ALL	NPT	1	-	-	-	-
3" - 4"	DI	125#RF	2	250#RF	3	-	-
1" - 4"	CS / SST	150#RF	4	300#RF	5	600#RF	8

POSITION 14 - SPRING CHAMBER OPTIONS		
Description	Option	CODE
No Option	-	0
SST Rain proof Bug Vent.	-25S	H

POSITION 11 - PILOT SPRING RANGE			
Set Point Range	NON-NACE	NACE	
in WC	mbarg	CODE	CODE
2"-41"WC *	4.9-101	1	G
13"-41"WC	32-101	2	H
psig	barg		
1-5	.07-.34	3	J
3-10	.20-.68	4	K
7-20	.48-1.3	5	L
15-50	1.0-3.4	6	M
40-100	2.7-6.8	7	N
90-200	6.2-13.7	8	P

POSITION 12 - TUBING		
Material	External Sensing *	Self Contained Sensing
	CODE	
Brass	B	C
Stainless Steel **	S	T
For Special Construction Contact Cashco for Special Code	X	

POSITION 15 - BODY OPTIONS		
Description	Option	CODE
No Option	-	0
Second Set 1/4" (DN8) FNPT Pressure Taps & Plugs.	-85	T

POSITION 16 - CERTIFICATE OPTIONS		
Description	Option	CODE
No Option	-	0
NACE CONST: CS/CS, LCC/LCC or SST/SST.Per MR0175	-40	J
SPECIAL CLEANING: Per Spec #S-1134. W/ properly selected mat'ls. Suitable for Oxygen Service. SST body material.	-55	M
Special Cleaning: Per Cashco Spec #S-1542.	-56	N

POSITION 13 - FEATURE OPTIONS		
Description	Op-tion.	CODE
No Option	-	0
Coalescing Filter element.	-21	C
System Supply Gauge for Outlet of Stabilizer.	-86	U

POSITION 17 - PAINT OPTIONS		
Description	Option	CODE
No Option	-	0
Epoxy Painted Per Cashco Spec #S-1687.	-95OS	Y

Cashco, Inc.  
P.O. Box 6  
Ellsworth, KS 67439-0006  
PH (785) 472-4461  
FAX (785) 472-3539  
www.cashco.com  
e-mail: sales@cashco.com  
Printed in U.S.A. PGR-1-TB

Cashco GmbH  
Handwerkerstrasse 15  
15366 Hoppegarten, Germany  
PH +49 3342 30968 0  
Fax. No. +49 3342 30968 29  
www.cashco.com  
email: germany@cashco.com

Cashco do Brasil, Ltda.  
Al.Venus, 340  
Indaiatuba - Sao Paulo, Brazil  
PH +55 11 99677 7177  
Fax. No.  
www.cashco.com  
email: brazil@cashco.com