



MODEL DA2



CAUTION

In the event of diaphragm failure, the process fluid will mix with the loading fluid.

APPLICATIONS

The "DO-ALL" design allows application of all types of clean fluids. Designed primarily for gaseous and liquid service applications where excessive cavitation is absent. Excellent for atmospheric industrial gases – GN₂, GOX, Ar, He, H₂, CO₂ – as well as a natural gas regulator. Used as a utilities – air, oil, water, steam – regulator. Non-corrosive chemical services – gas or liquid – are possible with broad materials range.

MODEL DA2

DO-ALL SERIES II

DIFFERENTIAL PRESSURE REDUCING REGULATORS

Spring Operated 1/2" – 4" (DN15 - 100)

The Model DA2 is a differential reducing regulator used to maintain a constant pressure differential between a fluid loading pressure (P_{LOAD}) piped to the spring chamber and the regulator's outlet pressure (P_2). In the Model DA2 the P_2 pressure is higher than the P_{LOAD} (Positive Bias). The amount of bias or differential pressure (ΔP_{Diff}) is controlled by the user adjustable setting of the range spring in the spring chamber.

The regulator uses a flow-to-open, cage balanced trim. The diaphragm is isolated from the fluid flow path by a balancing piston, which allows the user to specify either internal or external sensing of the P_2 pressure.

FEATURES

- | | |
|----------------------------|---|
| Versatile: | Four basic materials and multiple trim material combinations to select from. |
| Tight Shutoff: | Multiple composition materials provide Class IV or VI inboard leakage rates. Designed as a soft-seated valve. |
| Capacity: | Highest in the industry. Allows smaller body sizes than competitors in majority of applications. |
| Pressure Drop: | Highest in the industry when coupled with high flow capacity. |
| Trim Design: | "DO-ALL" trim design provides <u>FTO</u> and <u>pressure balancing</u> for higher inlet pressure. Results in unmatched <u>sensitivity</u> and <u>stability</u> . Internals are <u>cage-contained</u> within easily removable <u>quick change trim</u> . |
| Rangeability: | Basic valve gives outstanding rangeability due to close tolerances, balanced trim, and a broad range of elastomeric diaphragms and soft seats. Can be as high as 1000:1. |
| Heavy-Duty Guiding: | Both top and bottom guided to maintain stability and increased diaphragm life. |
| Failure Position: | DA2 fails open on loss of P_1 or P_2 pressures. |

STANDARD / GENERAL SPECIFICATIONS

Body/Spring Chamber Materials

DI/DI	BRZ/BRZ *	BRZ/SST
CS/DI	BRZ/DI	SST/DI
CS/CS	BRZ/CS	SST/CS
		SST/SST

* Through 2" (DN50) body size only.
 DI = Ductile Iron CS = Carbon Steel BRZ = Bronze
 SST = Stainless Steel

Body Sizes

1/2", 3/4", 1", 1-1/4", 1-1/2", 2", 3", 4"
 (DN15, 20, 25, 32, 40, 50, 80, 100)

End Connections

Standard: Female NPT (screwed).
ASME Flanged: 125#, 150#, 250#, 300#, 600#;
DIN Flanged: PN16, PN25, PN40;
 (Integral Flanged Body unless listed under Opt.-30)
 Opt-31: British Standard Pipe Threads
 Opt-32: Schedule 80 Extended Pipe Nipples.
 Opt-34: 14" Face to Face Flange Dimension.
 Opt-41: Extension Tube Ends.

Recommended Max. Useable Cv

Body Size		Diaphragm		Body Size		Diaphragm	
in	(DN)	Comp.	Metal	in	(DN)	Comp.	Metal
1/2"	(15)	3.6	3.5	2"	(50)	54	12
3/4"	(20)	7.2	3.5	3"	(80)	108	N/A
1"	(25)	13.5	3.5	4"	(100)	196	N/A
1-1/4"	(32)	20.7	6.0	-	-	-	-
1-1/2"	(40)	27.0	6.0	-	-	-	-
		Cv	Cv			Cv	Cv

See Table DAG-6 for Wide Open Cv Limits.
 See Tables 3A through 3D and 4A through 4C for Cv vs.
 Droop vs. Range Spring tables.

Inlet Pressure Range

Operating: 10–3705 psig (.69-255 Barg).
 See Tables DAG-1A – 1F for design P vs. T limits.

Differential Pressure Range

1/2"–1"(DN15–25): 1 to 200 psid (.07 to 13.8 Bard)
 1-1/4"–1-1/2" (DN32–DN40): 1 to 125 psid (.07 to 8.6 Bard)
 2" (DN50): 1 to 90 psid (.07 to 6.2 Bard)
 3"–4"(DN80–100): 1 to 125 psid (.07 to 8.6 Bard)

NOTE: Ranges may be limited by diaphragm selection.
 See Table 5

Pressure Drop Limits

5–1500 psid (.34-103.4 Bard)
 Function of service fluid, base trim material, diaphragm and
 dynamic seal design. See Table 5 and Table DAG-2, DAG-3
 & DAG-4.

Temperature Range

-425° to +400°F (-254° to +204° C)
 Limited by body/sp.ch. material combinations, and by
 elastomeric – diaphragm, seat, static seal, dynamic
 seal – materials. See Tables DAG-1A through 1F and
 Table DAG-5.
Alternate "CS" Mat'l - Steel - ASTM A352 Gr. LCC - Minimum
 temperature -50 °F (-46 °C).

Inboard Leakage Rates

See Table DAG-10

Optional Constructions

- | | |
|---|---|
| <p><u>Opt-30:</u> Weld-on Flanges
 <u>Opt-31:</u> BSP End Conns.
 <u>Opt-32:</u> Ext. Pipe Nipples
 <u>Opt-34:</u> 14" F to F Flange Dim.
 <u>Opt-41:</u> Ext. Tube Ends
 <u>Opt-55:</u> Oxygen Cleaned
 <u>Opt-56:</u> Special Cleaned</p> | <p><u>Opt-57:</u> Chlorine Cleaned
 <u>Opt-65:</u> Flow-thru Spr. Chmb.
 <u>Opt-81:</u> Full Diaph. Support
 <u>Opt-85:</u> Extra Set Press. Taps
 <u>Opt-95:</u> Epoxy Paint
 <u>Opt-95OS:</u> Epoxy Paint</p> |
|---|---|

ABBREVIATIONS		
FK = Fluorosilicone	NBR = Buna-N	PTFE = Polytetrafluoroethylene
FKM = Fluorocarbon Elastomer	RTFE = Brz-fill TFE	V-TFE = Virgin TFE
EPR = Ethylene Propylene	GF-TFE = Glass-fill TFE	CTFE = Chlorotrifluoroethylene
BC = Neoprene	PA = PolyAll	3-ply (PTFE+FKM+PTFE)

MATERIAL SPECIFICATIONS

Body

- DI – ASTM A395
CS – ASTM A216, Grade WCB.
 Alternate ASTM A352 Gr. LCC
BRZ – ASTM B62, Alloy 83600,
SST – ASTM A351, Grade CF3M.

See DAG-1A through DAG-1F for material specs.

Spring Chamber

- DI – ASTM A395
CS – Sizes 1/2" - 2" ASTM A216 Gr. WCB;
 Alternate ASTM A352 Gr. LCC
 Sizes 3" & 4" ASTM A516 Gr. 55, A106 Gr. B;
BRZ – ASTM B62, Alloy 83600.
SST – Sizes 1/2" - 2" ASTM A351 Gr. CF3M;
 Sizes 3" & 4" ASTM A479 Gr. 316L, A312 Gr.316L

Diaphragm *

Elastomeric – BC, EP, FKM, FK, NBR, FKM+TFE,
 3-ply (PTFE+FKM+PTFE).

Metallic – Be-Cu. (only 1/2" - 2" sizes)

Metallic Trim *

17-4PH SST, 316L SST, Nickel-Copper Alloy (Monel[†]).
 See Table 2.

Seat *

PolyAll, V-TFE, GF-TFE, CTFE, BC, NBR, FKM

Static Seals (See Fig. DAG-F1) *

RTFE, NBR, FKM, FK, EP, - o-ring
 SST/TFE (1/2" - 2") (DN15 - 50) sizes,
 V-TFE (3" - 4") (DN80 - 100) sizes.

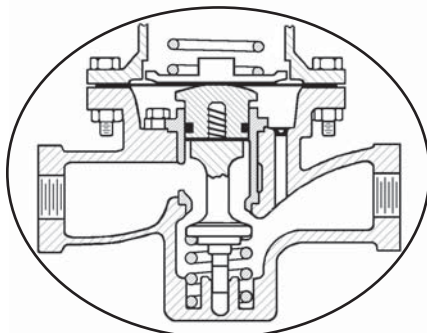

Metal Diaphragm

This construction
REQUIRES a Lower
 Piston Spring to be
 supplied.

Dynamic Seals (See Fig. DAG-F1) *

- Type OR – NBR, FKM, EP, - o-ring seal.
Type CW – TFE cap seal with o-ring energizer
 (o-ring material same as static seal)
 and GF-TFE wiper backup seal.
Type UC – V-TFE u-cup seal with 316L SST energizer.
 - V-TFE u-cup seal with Elgiloy energizer.
Type PW – GF-TFE piston ring assembly seal with
 17-7PH SST energizer; and GF-TFE wiper
 backup seal.

Painting

Standard: All non-corrosion resistant portions to be painted
 with corrosion resistant epoxy paint per Cashco Spec #S-1606.

Alternate: See Opt-95 or Opt-95OS.

* See Product Coder for acceptable combinations.

[†]Monel[™], and Inconel[®] are registered trade names:
 Monel[™] is a mark owned by International Nickel Co.
 Inconel[®] is a mark owned by International Nickel Co.

See Fig. DAG-1

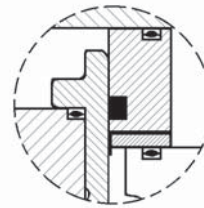

**Dynamic &
 Static Seals**

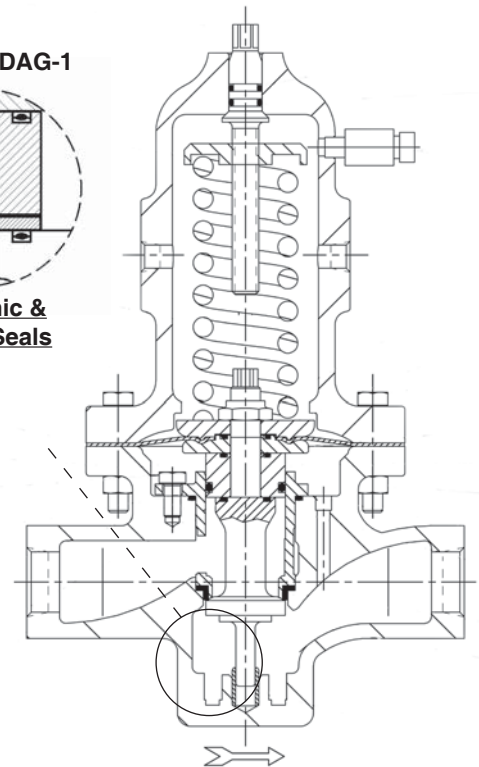

Composition Diaphragm

OPTION SPECIFICATIONS

OPT-30: WELDED FLANGED CONNECTIONS. CS, or SST body materials only. 1/2"-2" (DN15-50) body sizes only (no 1-1/4" (DN32) size). Welded-on flange of same general chemistry as body.

Weld-On Flanges		
Sizes	Body Material	ASME Pressure Class
1/2" - 3/4"	CS, SST	150, 300, 600
1"	CS, SST	600
Sizes	Body Material	ISO Pressure Class
DN15-50	CS, SST	PN40 RF
DN80-100	CS, SST	PN16, 25, 40 RF

NOTES: 1. The body P vs. T ratings are the limiting variables for flanged end connections, unless further restricted by ASME B16.5.
2. No post-weld stress relieving performed.

OPT-31: BSP END CONNECTIONS. British Standard Pipe threads per ISO 7/1; used as an alternate to NPT ends. 1/2" – 2" (DN15-50) sizes only.

OPT-32: EXTENDED PIPE NIPPLES. Sch. 80 extension pipe nipples available for CS and SST bodies; for body sizes 1/2" – 2" (DN15-50) only.

OPT-34: SPECIAL 14" FACE TO FACE DIMENSION FOR FLANGED END CONNECTIONS. Sizes 1/2" - 1" & 1-1/2" only. See Opt.-30 for standard face to face dimension.

OPT-41: EXTENDED TUBE END CONN. SST body material only. Body sizes 1/2"-1" (DN15-25), 1-1/2" & 2" (DN40-50) only. SST extension tubes are welded to body, ending in tube diameters with 0.065 inch (1.65 mm) wall thickness. **NOT FOR HIGH PURITY REQUIREMENTS.**

OPT-55: SPECIAL CLEANING - GOX. BRZ or SST body materials only. Cleaning, assembly and packaging per Cashco Spec #S-1134, making unit suitable for Oxygen Service. **NOTE: Design Pressure Rating shall not exceed 375 psig (25.8 Barg) when body/topworks material is SST and process medium is oxygen.**

OPT-56: SPECIAL CLEANING. Cleaning per Cashco Spec. #S-1542 for all body & spring chamber materials. Higher cleaning level than standard commercial cleaning. NOT suitable for Oxygen Service.

OPT-57: SPECIAL CLEANING - Cl₂. CS or SST materials only. Cleaning per Cashco Spec. #S-1589. For chlorine gas/liquid service.

OPT-65: FLOW-THRU SPRING CHAMBER. Spring chamber provided with two female NPT connections on spring chamber, allowing loading pressurizing fluid to be recirculated. Recommended for heavy oils with high paraffin content. CS spring chamber only. Tapped connection sizes dependent on body size.

OPT-81: FULL DIAPHRAGM SUPPORT CONSTRUCTION. Incorporates top and bottom diaphragm support that allows reaching higher fluid pressures on the underside and topside of diaphragm. Sizes 1/2"-2" (DN15-50) only. See Table 5.

OPT-85: PRESSURE TAPS. Provides second set of inlet and outlet 1/4" (DN8) - FNPT taps with plugs (same basic material as body) on backside of body. Includes second external sensing port tap. See page 22 for details on tap location for both STD. and Opt -85.

OPT-95: EPOXY PAINT. Special epoxy painting of all non-corrosion resistant external surfaces per Cashco Spec #S-1547. Utilized in harsh atmospheric conditions.

OPT-95OS: EPOXY PAINT. Special epoxy painting of all non-corrosion resistant external surfaces per Cashco Spec #S-1687. Utilized in OFFSHORE atmospheric conditions.

TECHNICAL SPECIFICATIONS

**TABLE 1
RANGE SPRINGS**

Body Size in. (DN)	Spring Range psid	Body Size in. (DN)	Spring Range psid
1/2" (15) 3/4" (20) 1" (25)	1-5* 1-10**	2" (50)	1-5* 1-10**
	5-20 10-35 20-80 30-150 70-200		5-15 10-30 15-50 30-90
1-1/4" (32) 1-1/2" (40)	1-5* 1-10**	3" (80) 4" (100)	1-10
	5-20 10-40 10-70 40-175		5-20 10-40 10-70 40-125

* Composition diaphragm construction ONLY.

** Metal diaphragm for set point pressure \geq 5 psid (.34 Bard).

METRIC CONVERSION: psid / 14.5 = Bard

**TABLE 2
METALLIC TRIM MATERIAL COMBINATIONS**

PART	TRIM DESIGNATION			
	S	P	M	T
Plug	316L SST	17-4 PH SST	Monel†	17-4 PH SST
Guide Bearing	316L SST	17-4 PH SST	Monel†	17-4 PH SST
Cage	316L SST	316L SST	Monel†	Monel†
Body Bushing	Monel†	17-4 PH SST	Monel†	Monel†

† See Page 3 for registered trade name information.

TABLE 3A
FULL PORT FLOW CAPACITY – Cv
COMPOSITION DIAPHRAGM $F_L = 0.90$

Differential Pressure ΔP_{Diff} psid	Cv Capacity @ % Droop									Range Spring psid
	BODY SIZE - 1/2" (DN15)			BODY SIZE - 3/4" (DN20)			BODY SIZE - 1" (DN25)			
	10%	20%	30%	10%	20%	30%	10%	20%	30%	
1	1.08	2.00	2.70	1.35	2.50	3.38	1.51	2.79	3.76	1 to 5
3	3.06	3.24	3.42	4.05	6.48	6.84	4.51	8.34	11.25	
5	3.06	3.24	3.42	5.85	6.48	6.84	6.51	12.04	12.83	
1	0.52	0.96	1.29	0.66	1.22	1.65	0.71	1.31	1.76	1 to 10
5	3.06	3.24	3.42	3.29	6.09	6.84	4.31	7.97	10.75	
10	3.06	3.24	3.42	5.60	6.48	6.84	6.15	11.38	12.83	
5	2.16	3.24	3.42	2.71	5.01	6.76	3.00	5.55	7.49	5 to 20
10	3.06	3.24	3.42	4.28	6.48	6.84	4.75	8.79	11.87	
15	3.06	3.24	3.42	5.18	6.48	6.84	5.75	10.64	12.83	
20	3.06	3.24	3.42	6.12	6.48	6.84	8.35	12.15	12.83	
10	1.04	1.92	2.59	1.31	2.42	3.26	1.45	2.68	3.61	10 to 35
20	2.31	3.24	3.42	2.88	5.33	6.84	3.20	5.92	7.99	
30	3.06	3.24	3.42	4.68	6.48	6.84	5.20	9.62	12.83	
35	3.06	3.24	3.42	5.40	6.48	6.84	6.00	11.10	12.83	
20	0.79	1.46	1.97	0.99	1.83	2.47	1.11	2.05	2.76	20 to 80
40	1.33	2.46	3.32	1.67	3.09	4.17	1.85	3.42	4.61	
60	2.81	3.24	3.42	3.51	6.48	6.84	3.91	7.23	9.76	
80	3.06	3.24	3.42	4.91	6.48	6.84	5.45	10.08	12.83	
30	0.72	1.33	1.79	0.91	1.68	2.26	1.00	1.85	2.50	30-150
50	1.26	2.33	3.14	1.58	2.92	3.94	1.75	3.24	4.38	
75	2.16	3.24	3.42	2.71	5.01	6.76	3.00	5.55	7.49	
100	2.74	3.24	3.42	3.42	6.33	6.84	3.80	7.03	9.49	
125	3.06	3.24	3.42	4.51	6.48	6.84	5.00	9.25	12.49	
150	3.06	3.24	3.42	4.95	6.48	6.84	6.00	11.10	12.83	
70	0.54	1.00	1.35	0.68	1.26	1.70	1.18	2.18	2.94	70-200
100	1.73	3.20	3.42	2.16	4.00	5.41	2.40	4.44	5.99	
125	2.34	3.24	3.42	2.93	5.42	6.84	3.25	6.01	8.11	
150	2.74	3.24	3.42	3.42	6.33	6.84	3.80	7.03	9.49	
175	3.06	3.24	3.42	4.19	6.48	6.84	4.65	8.60	11.61	
200	3.06	3.24	3.42	5.04	6.48	6.84	4.71	8.71	11.75	

METRIC CONVERSION FACTORS: psid / 14.5 = Bard; $C_v / 1.16 = k_v$

TABLE 3B
FULL PORT FLOW CAPACITY – Cv
COMPOSITION DIAPHRAGM $F_L = 0.90$

Differential Pressure ΔP_{Diff} psid	Cv capacity @ % Droop						Range Spring psid
	BODY SIZE – 1-1/4" (DN32)			BODY SIZE – 1-1/2" (DN40)			
	10%	20%	30%	10%	20%	30%	
1	2.09	3.87	5.23	2.20	4.07	5.49	1-5
3	4.75	8.79	11.87	5.00	9.25	12.49	
5	7.79	14.41	19.45	8.20	15.17	20.48	
1	1.01	1.87	2.53	1.04	1.92	2.59	1-10
5	4.60	8.51	11.49	4.85	8.97	12.11	
10	7.25	13.41	18.10	7.91	14.63	19.75	
5	2.66	4.92	6.64	2.80	5.18	6.99	5-20
10	5.71	10.56	14.25	6.00	11.10	14.99	
15	8.59	15.89	19.67	9.41	17.41	23.51	
20	11.41	18.63	19.67	11.77	21.77	25.65	15-45
15	4.46	8.25	11.14	4.71	8.71	11.75	
25	7.41	13.71	18.51	7.80	14.43	19.48	
35	10.31	18.63	19.67	10.91	20.18	25.65	
45	13.41	18.63	19.67	15.06	24.30	25.65	10-70
10	1.56	2.89	3.91	1.65	3.05	4.11	
30	4.27	7.90	10.67	4.51	8.34	11.25	
50	7.36	13.63	18.39	7.75	14.34	19.36	
70	10.00	18.50	19.67	10.59	19.59	25.65	40-125
40	2.56	4.74	6.41	2.71	5.01	6.76	
50	3.80	7.03	9.49	4.00	7.40	9.99	
75	5.22	9.66	13.05	5.51	10.19	13.75	
100	6.88	12.73	17.19	7.25	13.41	18.10	
125	8.55	15.82	19.67	9.00	16.65	22.48	

TABLE 3C
FULL PORT FLOW CAPACITY – Cv
COMPOSITION DIAPHRAGM $F_L = 0.90$

Differential Pressure ΔP_{Diff} psid	Cv capacity @ % Droop			Range Spring psid
	BODY SIZE – 2" (DN50)			
	10%	20%	30%	
1	5.00	9.25	12.49	1-5
3	17.06	31.56	42.61	
5	27.53	48.60	51.30	
1	2.38	4.40	5.94	1-10
5	16.35	30.25	40.84	
10	26.00	48.10	51.30	
5	8.51	15.74	21.24	5-15
10	14.47	26.77	36.14	
15	22.35	41.35	51.30	
10	4.91	9.08	12.25	10-30
20	11.77	21.77	29.38	
30	17.65	32.65	44.07	
15	3.00	5.55	7.49	15-50
25	6.00	11.10	14.99	
35	8.71	16.11	21.74	
50	12.47	23.07	31.15	30-90
30	4.00	7.40	9.99	
60	8.20	15.17	20.48	
90	12.00	22.20	29.97	

METRIC CONVERSION FACTORS:
psid / 14.5 = Bar; $C_v / 1.16 = k_v$

TABLE 3D
FULL PORT FLOW CAPACITY – Cv
COMPOSITION DIAPHRAGM $F_L = 0.90$

Pressure Setpoint ΔP_{Diff} psid	Cv Capacity @ % Droop						Range Spring psid
	BODY SIZE – 3" (DN80)			BODY SIZE – 4" (DN100)			
	10%	20%	30%	10%	20%	30%	
1	7.00	12.95	17.48	15.06	27.86	37.61	1-10
3	15.06	27.86	37.61	20.00	37.00	49.95	
5	29.06	53.76	72.58	35.06	64.86	87.56	
10	62.35	97.20	102.60	75.30	139.30	188.05	
5	13.53	25.03	33.79	30.00	55.50	74.93	5-20
10	27.06	50.06	67.58	48.00	88.80	119.88	
15	45.06	83.36	102.60	75.30	139.30	188.05	
20	64.71	97.20	102.60	100.00	178.20	188.10	
10	14.00	25.90	34.97	25.06	46.36	62.59	10-40
20	34.59	63.99	86.39	51.06	94.46	127.52	
30	52.00	96.20	102.60	70.59	139.30	176.30	
40	67.06	97.20	102.60	104.71	178.20	188.10	
10	5.00	9.25	12.49	8.00	14.80	19.98	10-70
30	15.06	27.86	37.61	27.53	50.93	68.76	
50	28.00	51.80	69.93	48.47	89.67	121.06	
70	49.30	91.20	102.60	67.06	124.06	167.48	
40	12.00	22.20	29.97	25.06	46.39	62.59	40-125
50	17.06	31.56	42.61	29.53	54.63	73.75	
75	27.53	50.93	68.76	40.00	74.00	99.90	
100	36.00	66.60	89.91	48.00	88.80	119.88	
125	42.47	78.57	102.60	57.06	105.56	142.51	

METRIC CONVERSION FACTORS: psid / 14.5 = Bard; $C_v / 1.16 = k_v$

TABLE 4A
FULL PORT FLOW CAPACITY – Cv
METAL DIAPHRAGM $F_L = 0.90$

Pressure Setpoint ΔP_{Diff} psid	Cv Capacity @ % Droop									Range Spring psid
	BODY SIZE – 1/2" (DN15)			BODY SIZE – 3/4" (DN20)			BODY SIZE – 1" (DN25)			
	10%	20%	30%	10%	20%	30%	10%	20%	30%	
5	1.24	2.30	3.10	1.32	2.44	3.29	1.72	3.15	3.33	1-10
10	1.66	3.06	3.33	2.24	3.15	3.33	2.46	3.15	3.33	
5	0.87	1.60	2.16	1.08	2.00	2.70	1.20	2.22	3.00	5-20
10	1.37	2.53	3.33	1.71	3.15	3.33	1.90	3.15	3.33	
15	1.66	3.06	3.33	2.07	3.15	3.33	2.30	3.15	3.33	
20	1.66	3.06	3.33	2.98	3.15	3.33	2.98	3.15	3.33	
10	0.41	0.77	1.03	0.52	0.97	1.30	0.58	1.07	1.45	10-35
20	0.92	1.71	2.30	1.15	2.13	2.88	1.28	2.37	3.20	
30	1.50	2.77	3.33	1.87	3.15	3.33	2.08	3.15	3.33	
35	1.60	2.96	3.33	2.16	3.15	3.33	2.40	3.15	3.33	
20	0.32	0.58	0.79	0.40	0.73	0.99	0.44	0.82	1.10	20-80
40	0.53	0.98	1.33	0.67	1.24	1.67	0.74	1.37	1.85	
60	1.12	2.08	2.81	1.40	2.59	3.33	1.56	2.89	3.33	
80	1.57	2.90	3.33	1.96	3.15	3.33	2.18	3.15	3.33	
30	0.29	0.53	0.72	0.36	0.67	0.90	0.40	0.74	1.00	30-150
50	0.50	0.93	1.26	0.63	1.17	1.57	0.70	1.30	1.75	
75	0.87	1.60	2.16	1.08	2.00	2.70	1.20	2.22	3.00	
100	1.10	2.03	2.74	1.37	2.53	3.33	1.52	2.81	3.33	
125	1.44	2.66	3.33	1.80	3.15	3.33	2.00	3.15	3.33	
150	1.59	2.93	3.33	1.98	3.15	3.33	2.40	3.15	3.33	
70	0.22	0.40	0.54	0.27	0.50	0.68	0.47	0.87	1.18	70-200
100	0.69	1.28	1.73	0.87	1.60	2.16	0.96	1.78	2.40	
125	0.94	1.73	2.34	1.17	2.17	2.93	1.30	2.40	3.24	
150	1.10	2.03	2.74	1.37	2.53	3.33	1.52	2.81	3.33	
175	1.34	2.48	3.33	1.68	3.10	3.33	1.86	3.15	3.33	
200	1.60	2.96	3.33	2.01	3.15	3.33	1.88	3.15	3.33	

METRIC CONVERSION FACTORS: psid / 14.5 = Bard; $C_v / 1.16 = k_v$

TABLE 4B
FULL PORT FLOW CAPACITY – Cv
DA2 - METAL DIAPHRAGM
F L = 0.90

Pressure Setpoint ΔP_{Diff} psid	Cv capacity @ % Droop						Range Spring psid
	BODY SIZE – 1-1/4" (DN32)			BODY SIZE – 1-1/2" (DN40)			
	10%	20%	30%	10%	20%	30%	
5	1.84	3.40	4.60	1.94	3.59	4.84	1-10
10	2.90	5.36	5.70	3.16	5.40	5.70	
5	1.06	1.97	2.66	1.12	2.07	2.80	5-20
10	2.28	4.22	5.70	2.40	4.44	5.70	
15	3.44	5.40	5.70	3.76	5.40	5.70	
20	4.56	5.40	5.70	4.71	5.40	5.70	
15	1.78	3.30	4.45	1.88	3.48	4.70	15-45
25	2.96	5.40	5.70	3.12	5.40	5.70	
35	4.12	5.40	5.70	4.36	5.40	5.70	
45	5.10	5.40	5.70	5.10	5.40	5.70	
10	0.63	1.16	1.56	0.66	1.22	1.65	10-70
30	1.71	3.16	4.27	1.80	3.33	4.50	
50	2.95	5.40	5.70	3.10	5.40	5.70	
70	4.00	5.40	5.70	4.24	5.40	5.70	
40	1.03	1.90	2.56	1.08	2.00	2.70	40-125
50	1.52	2.81	3.80	1.60	2.96	4.00	
75	2.09	3.87	5.22	2.20	4.07	5.50	
100	2.75	5.09	5.70	2.90	5.36	5.70	
125	3.42	5.40	5.70	3.60	5.40	5.70	

TABLE 4C
FULL PORT FLOW CAPACITY – Cv
DA2 - METAL DIAPHRAGM
F L = 0.90

Pressure Setpoint ΔP_{Diff} psid	Cv capacity @ % Droop			Range Spring psid
	BODY SIZE – 2" (DN50)			
	10%	20%	30%	
5	6.54	10.80	11.40	1-10
10	10.20	10.80	11.40	
5	3.40	6.29	8.50	5-15
10	5.79	10.71	11.40	
15	8.94	10.80	11.40	
10	1.96	3.63	4.90	10-30
20	4.71	8.71	11.40	
30	7.06	10.80	11.40	
15	1.20	2.22	3.00	15-50
25	2.40	4.44	5.99	
35	3.48	6.44	8.70	
50	4.99	9.23	11.40	
30	1.60	2.96	4.00	30-90
60	3.28	6.07	8.19	
90	4.80	8.88	11.40	

METRIC CONVERSION FACTORS:
psid / 14.5 = Barg; $C_v / 1.16 = k_v$

TABLE 5
MAXIMUM DIAPHRAGM RATING *
psig (Barg)

NOTE: The below ratings may be further "derated" by limitations thru the Pressure Equipment Directive (97/23/EC-May '97).

DIAPHRAGM MATERIAL	BODY SIZE 1/2" - 2" (DN15-50)		BODY SIZE 3" - 4" (DN80-100)
	STD DIAPHRAGM CONSTRUCTION	** OPT-81 FULL DIAPHRAGM SUPPORT	STD DIAPHRAGM CONSTRUCTION
	P_2 MAX	P_2 MAX	P_2 MAX
BC, EPR	1250 (86.1)	1250 (86.1)	800 (55.1)
NBR	450 (31.0)	1250 (86.1)	300 (20.6)
FKM, FKM+TFE, FK	700 (48.2)	1250 (86.1)	550 (37.9)
3-ply (PTFE+FKM+PTFE) ***	125 (8.6)	125 (8.6)	125 (8.6)
METAL Be-Cu	1500 (103)	NA	NA

*Maximum setting of pressure safety device – safety relief valve or rupture disc.

**Not available for DI/DI, BRZ/DI, BRZ/BRZ, BRZ/CS, BRZ/SST, CS/DI & SST/DI constructions.

*** For Steam applications.

NA = NOT AVAILABLE

DAG TECHNICAL APPENDIX INDEX

<u>TABLE</u>	<u>TITLE</u>	<u>PAGE</u>
DAG-1A	DI – Press vs Temp vs End Conn Ratings	11
DAG-1B	BRZ – Press vs Temp vs End Conn Ratings	12
DAG-1C	CS – Press vs Temp vs End Conn Ratings - Design Inlet	13
DAG-1D	Design Outlet - DA2	13
DAG-1E	SST – Press vs Temp vs End Conn Ratings – Design Inlet	14
DAG-1F	Design Outlet - DA2	14
DAG-2	Max Pressure Drop - Comp Seat	15
DAG-3	Max Pressure Drop - Dynamic Seal Design	15
DAG-4	Max Pressure Drop - Basic Trim Mat'ls	15
DAG-5	Temperature Limits – Elastomer Mat'ls	16
DAG-6	Reducer Max Capacity - Plug Wide Open	17
DAG-9	Reducer Lower Piston Spring range	17
DAG-10	Inboard Leakage Ratings	18
DAG-11	Reducer Recommended Velocity Limits	18
DAG-13	Max Recommended Noise Limits	18
DAG-14	Recommended Internal Materials - Liquids	19
DAG-14	Recommended Internal Materials - Gases	19
DAG-14	Supplement - Chemical Resistance	20
DAG-15	ISR Effect	20
FIGURE		
DAG-F1	Dynamic/Static Seals	21
DAG-F2	Location of Body/Spring Chamber Taps	22

TABLE DAG-1A
DI – DUCTILE IRON
BODY / TOPWORKS MATERIAL SPECIFICATIONS
DESIGN PRESSURE vs. TEMPERATURE vs. END CONNECTION RATINGS
(To ASME B16.1 for Flanged and B16.4 for NPT Connections per Cast Iron Rating)

Material Specifications (Body / Topworks)		End Connection – Inlet & Outlet					
		Temperature °F	Working Pressure – psig				
Description (Abbr.)	ASTM No.		End Connection – Pressure Class				
			NPT	125# FF	250# RF		
DI/DI (Note 1)	A395/ A395	-20° to +150°	400	200	500		
		200°	370	190	460		
		225°	355	180	440		
		250°	340	175	415		
		300°	310	165	375		
		350°	300	150	335		
		400°	250	140	290		
		406°	250	140	290		
			400 WOG, 250 S	225 WOG, 125 S	400 WOG, 250 S		
				Working Pressure – Barg			
				End Connection – Pressure Class			
				NPT	125# FF	250# RF	
				-29° to +65°	27.6	13.8	34 .5
				107	24.5	12.5	30.2
				120°	23.4	12.1	28.7
		150°	21.2	11.2	25.7		
		177°	19.2	10.6	23.8		
		204°	17.5	9.6	20.3		

NOTE 1: Whenever body and topworks materials are mixed, the P vs. T ratings that should be applied are those which are lowest of the two materials.

Example: CS body, DI topworks; NPT end connections, 200°F temperature.

Because the topworks is not “end flanged”, use the DI limits of “400 PSIG CWP 370/200F” from above to compare to CS limits from DAG-1C values. The DI limits are lower, so ratings from DAG-1A MUST be used as the limits.

NOTE 2: Unless stated otherwise, design pressure is Maximum Allowable Working Pressure (MAWP) for Inlet and Outlet.

**TABLE DAG-1B
BRZ – BRONZE
BODY / TOPWORKS MATERIAL SPECIFICATIONS**

**DESIGN PRESSURE vs. TEMPERATURE vs. END CONNECTION RATINGS
(Per ASME B16.24 for Flanged and B16.15 for NPT Connections)**

Material Specifications (Body / Topworks)		End Connection – Inlet & Outlet (Note 2)					
Description (Abbr.)	ASTM No.	Temperature °F	Working Pressure – psig				
			End Connection – Pressure Class				
			NPT	150# FF	300# FF		
BRZ/BRZ (Note 1)	B62, Alloy C83600/B62, Alloy C83600	-325° to +150° *	700 † / 500	225	500		
		175°	390	220	480		
		200°	385	210	465		
		225°	375	205	445		
		250°	365	195	425		
		300°	335	180	390		
		350°	300	165	350		
		400°	250	150	315		
		406°	250	150	315		
				Working Pressure – Barg			
				End Connection – Pressure Class			
				NPT	150# FF	300# FF	
				-198° to +65° *	48.3 † / 34.5	15.5	34.5
				107°	25.8	14.0	30.8
				120°	25.1	13.5	29.5
				150°	23.0	12.4	26.8
				177°	20.4	11.3	24.0
				204°	17.8	10.3	21.4

NOTE 1: Whenever body and topworks materials are mixed, the P vs. T ratings that should be applied are those which are lowest of the two materials.

Example: BRZ body, DI topworks; NPT end connections, ambient temperature.

Because the topworks is not "end flanged", use the DI limits of "400 PSIG CWP 370/200F" from DAG-1A to compare to above DAG-1B values. The DI limits are lower, so ratings from DAG-1A MUST be used as the limits.

NOTE 2: Unless stated otherwise, design pressure is Maximum Allowable Working Pressure (MAWP) for Inlet and Outlet.

† For Pressure Reducing Regulator DA2 use 700 psig (48.2 Barg) inlet / 500 psig (34.4 Barg) outlet at 150°F as maximum limits.

* See Minimum Temperature Ratings Table below.

**DESIGN PRESSURE RATING
AT MIN. TEMPERATURE**

Regulator Function	Material Specifications (Body / Topworks - Connections) Description (Abbr.)	Pressure at Min. Temperature
Pressure Reducing	BRZ/BRZ - NPT	Inlet - 700 psig CWP to -325°F (-198°C)
		Outlet - 500 psig CWP to -325°F (-198°C)
	SST/SST - NPT, BSP, Ext. Nipples, Tube Ends and 600# Flgs	Inlet - 1440 psig CWP to -425°F (-254°C)
		Outlet - 625 psig CWP to -425°F (-254°C)

Body Material Specifications

Cast Steel A216 Gr. WCB or Steel Weldment A216 Gr. WCB w/ forged flanges A105

Alternate Material: Cast Steel A352 Gr. LCC or Steel Weldment A352 Gr. LCC w/ forged flanges A350 Gr. LF6 Class 2

Topworks Material Specifications

Cast Steel A216 Gr. WCB or Steel Weldment A516 Gr. 55 & A105

Alternate Material: Cast Steel A352 Gr. LCC

DESIGN PRESSURE vs. TEMPERATURE vs. END CONNECTION RATINGS
(Per ASME B16.5 and B16.34) See NOTE 1

TABLE DAG-1C					
DESIGN INLET PRESSURE FOR DA2					
in PSIG (BARG)					
CONSTRUCTION	END CONNECTIONS				
	STD DIAPHRAGM	ALL			Opt-81 (Full Support Diaph.) DA2
DESIGN TEMP. RANGE: Deg F (Deg C) **	NPT, BSP	600#, EXTD NIPP	150#	300#	NPT, BSP
-20 to +100 (-29 to +38)	1480 (102.1)	1480 (102.1)	285 (19.6)	740 (51.1)	3705 (255.3)
-20 to +200 (-29 to +93)	1360 (94.2)	1360 (94.2)	260 (17.9)	680 (47.1)	3375 (235.5)
-20 to +300 (-29 to +149)	1310 (90.3)	1310 (90.3)	230 (15.8)	655 (45.1)	3280 (225.6)
-20 to +400 (-29 to +204)	1265 (87.3)	1265 (87.3)	200 (13.7)	635 (43.6)	3170 (218.3)

** Alternate Mat'l: ASTM 352 Gr. LCC Minimum Temperature -50 °F (-46 °C).

TABLE DAG-1D				
DESIGN OUTLET PRESSURE FOR DA2				
in PSIG (BARG)				
CONSTRUCTION	END CONNECTIONS			
	STD DIAPHRAGM	ALL		Opt-81 (Full Support Diaph.) DA2
DESIGN TEMP. RANGE: Deg F (Deg C) **	NPT, BSP, 600#, EXTD NIPP	150#	300#	NPT, BSP, 600#, EXTD NIPP
-20 to +100 (-29 to +38)	750 (51.7)	285 (19.6)	740 (51.1)	1350 (93.0)
-20 to +200 (-29 to +93)	680 (47.1)	260 (17.9)	680 (47.1)	1350 (93.0)
-20 to +300 (-29 to +149)	655 (45.1)	230 (15.8)	655 (45.1)	1310 (90.3)
-20 to +400 (-29 to +204)	635 (43.6)	200 (13.7)	635 (43.8)	1265 (87.3)

** Alternate Mat'l: ASTM 352 Gr. LCC Minimum Temperature -50 °F (-46 °C).

NOTE 1: These pressure ratings may be further derated by limitations thru the Pressure Equipment Directive (97/23/EC-May '97). Whenever body and topworks are mixed, the P vs. T ratings that should be applied are those which are lowest for the two materials.

Example: 600 lb. RF flanged steel body, full support diaphragm construction, at 200 deg F maximum temp would have a preliminary inlet to 3375 psig and outlet to 1350 psig, but if fitted with a ductile iron topworks pressure rating is only 370 psig. Must derate both the inlet and outlet to 370 psig. (Note: Topworks pressure rating, same as NPT design outlet pressure rating for the selected topworks material and diaphragm type.

Body Material Specifications

Cast Stainless Steel A351 Gr.CF3M or Stainless Steel Weldment A315 Gr. CF3M w/ forged flanges A182 Gr. F 316L

Topworks Material Specifications

Cast Stainless Steel A351 Gr.CF3M or Stainless Steel Weldment A312 Gr. 316/316L, A479 Gr. 316/316L

DESIGN PRESSURE vs. TEMPERATURE vs END CONNECTION RATINGS (Per ASME B16.5 and B16.34) See NOTE 1

TABLE DAG-1E					
DESIGN INLET PRESSURE FOR DA2					
in PSIG (BARG)					
CONSTRUCTION *	END CONNECTIONS				
	STD DIAPHRAGM	ALL			Opt-81 (Full Support Diaph.) DA2
DESIGN TEMP. RANGE: Deg F (Deg C)	NPT, BSP	600#, EXTD NIPP, TUBE	150#	300#	NPT, BSP
-425 to +100 (-254 to +38)	1440 (99.3)	1440 (99.3)	275 (19.0)	720 (49.6)	3600 (248.2)
-20 to +200 (-29 to +93)	1240 (86.1)	1240 (86.1)	235 (16.5)	620 (43.0)	3095 (215.1)
-20 to +300 (-29 to +149)	1120 (77.1)	1120 (77.1)	215 (14.8)	560 (38.6)	2795 (192.9)
-20 to +400 (-29 to +204)	1025 (70.9)	1025 (70.9)	195 (13.6)	515 (35.5)	2570 (177.4)

TABLE DAG-1F				
DESIGN OUTLET PRESSURE FOR DA2				
in PSIG (BARG)				
CONSTRUCTION *	END CONNECTIONS			
	STD DIAPHRAGM	ALL		Opt-81 (Full Support Diaph) DA2
DESIGN TEMP. RANGE: Deg F (Deg C)	NPT, BSP, 600#, EXTD NIPP, TUBE	150#	300#	NPT, BSP 600#, EXTD NIPP, TUBE
-425 to +100 (-254 to +38)	625 (43.0)	275 (19.0)	625 (43.0)	1125 (77.5)
-20 to +200 (-29 to +93)	620 (42.3)	235 (16.5)	620 (42.3)	1125 (77.5)
-20 to +300 (-29 to +149)	560 (38.6)	215 (14.8)	560 (38.6)	1120 (77.0)
-20 to +400 (-29 to +204)	515 (35.5)	195 (13.6)	515 (35.5)	1025 (70.9)

* For Temperatures below -20°F - refer to page 11 for Design Pressure Rating at Min. Temperature.

NOTE 1: These pressure ratings may be further derated by limitations thru the Pressure Equipment Directive (97/23/EC-May '97). Whenever body and topworks are mixed, the P vs. T ratings that should be applied are those which are lowest for the two materials.

Example: 300 lb. RF flanged SST body, standard diaphragm construction, at 200 deg F maximum temp would have a preliminary inlet and outlet to 620 psig, but if fitted with a ductile iron topworks pressure rating is only 400 psig. Must derate both the inlet and outlet to 400 psig. (Note: Topworks pressure rating, same as NPT design outlet pressure rating for the selected topworks material and diaphragm type.

The ratings are the same as above, if substitute steel topwork material.

Maximum Design Pressure Rating for 2" Opt -41 limited by 0.065" wall thickness to 1200 psig.

300# Flanges are derated due to the bolting for these products.

**TABLE DAG-2
MAXIMUM PRESSURE DROP FOR
COMPOSITION SEATS**

Body Size		Max. Pressure Drop - psid (Bard)											
		Seat Material											
in	(DN)	BC, NBR, POLYALL *						GF-TFE					
		Liquid *		Gas		Steam		Liquid *		Gas		Steam √	
1/2" – 1"	(15-25)	600	(41.3)	750	(51.7)	DNA		450	(31.0)	1000	(68.9)	150/125	(10.3/8.6)
1-1/4" – 1-1/2"	(32-40)	600	(41.3)	600	(41.3)	DNA		450	(31.0)	900	(62.0)	150/125	(10.3/8.6)
2"	(50)	600	(41.3)	600	(41.3)	DNA		450	(31.0)	750	(51.7)	150/125	(10.3/8.6)
3" – 4"	(80-100)	500	(34.4)	600	(41.3)	DNA		450	(31.0)	750	(51.7)	125	(8.6)
		V-TFE						CTFE					
1/2" – 1"	(15-25)	300	(20.7)	600	(41.3)	125	(8.6)	600	(41.3)	3000	(206.9)	DNA	
1-1/4" – 1-1/2"	(32-40)	300	(20.7)	600	(41.3)	125	(8.6)	600	(41.3)	3000	(206.9)	DNA	
2"	(50)	300	(20.7)	600	(41.3)	125	(8.6)	600	(41.3)	2000	(137.9)	DNA	
3" – 4"	(80-100)	300	(20.7)	450	(31.0)	125	(8.6)	500	(34.4)	1500	(103.4)	DNA	

* Only seat material to be applied in liquid "partially cavitating" service is PolyAll.
 √ Steam Service: metal diaphragm/composition diaphragm.
 N/A = Not Available
 DNA = Do Not Apply

**TABLE DAG-3
MAXIMUM PRESSURE DROP FOR
DYNAMIC SEAL DESIGNS**

Body Size		Max. Pressure Drop - psid (Bard)																			
		Dynamic Seal Design																			
in	(DN)	"OR" – O-RING *						"CP" – TFE CAP						"CW" – TFE CAP w/WIPER							
		Liquid *		Gas *		Steam		Liquid		Gas		Steam		Liquid		Gas		Steam			
1/2" – 1"	(15-25)	600	(41.3)	750	(51.7)	DNA		600	(41.3)	600	(41.3)	DNA		450	(31.0)	600	(41.3)	DNA			
1-1/4" – 1-1/2"	(32-40)	600	(41.3)	750	(51.7)	DNA		600	(41.3)	600	(41.3)	DNA		450	(31.0)	600	(41.3)	DNA			
2"	(50)	600	(41.3)	750	(51.7)	DNA		600	(41.3)	600	(41.3)	DNA		450	(31.0)	600	(41.3)	DNA			
3" – 4"	(80-100)	600	(41.3)	750	(51.7)	DNA		600	(41.3)	600	(41.3)	DNA		450	(31.0)	600	(41.3)	DNA			
		"PR" – PISTON RING ASSY.						"PW" – PISTON RING ASSY. w/WIPER						"UC" – U-CUP							
1/2" – 1"	(15-25)	DNA		DNA		√	150/125	(10.3/8.6)	DNA		DNA		√	150/125	(10.3/8.6)	600	(41.3)	3000	(206.9)	DNA	
1-1/4" – 1-1/2"	(32-40)	DNA		DNA		√	150/125	(10.3/8.6)	DNA		DNA		√	150/125	(10.3/8.6)	600	(41.3)	3000	(206.9)	DNA	
2"	(50)	DNA		DNA		√	150/125	(10.3/8.6)	DNA		DNA		√	150/125	(10.3/8.6)	600	(41.3)	3000	(206.9)	DNA	
3" – 4"	(80-100)	DNA		DNA		125	(8.6)	DNA		DNA		125	(8.6)	600	(41.3)	3000	(206.9)	DNA		DNA	

* Only seat material to be applied in liquid "partially cavitating" or "flashing" service is PolyAll.
 √ Steam Service: metal diaphragm/composition diaphragm.
 N/A = Not Available DNA = Do Not Apply wo/ = without w/ = with

**TABLE DAG-4
MAXIMUM PRESSURE DROP FOR
BASIC TRIM MATERIAL**

Body Size		Max Pressure Drop - psid (Bard)									
		Basic Trim Material									
in	(DN)	"P" – 17-4PH SST		"S" – 316L SST		"M" – Monel		"T" – Hybrid *			
1/2" – 2"	(15-50)	3000	(206.9)	800	(55.1)	1500	(103.4)	3000	(206.9)		
3" – 4"	(80-100)	3000	(206.9)	800	(55.1)	1500	(103.4)	3000	(206.9)		

* 17-4PH SST plug & piston, Monel cage.

**TABLE DAG-5
TEMPERATURE LIMITS
FOR ELASTOMERIC MATERIALS**

Elastomer			T Maximum		T Minimum	
Seats	ID	Description	°F	(°C)	°F	(°C)
		PolyAll	Proprietary Polyurethane Derivative	225°	(107°)	-60°
	GF-TFE	Glass-filled Polytetrafluorethylene	425°	(218°)	-325°	(-198°)
	V-TFE	Virgin TFE	400°	(205°)	-325°	(-198°)
	CTFE	Chlorotrifluoroethylene TFE	300°	(148°)	-325°	(-198°)
	BC	Neoprene	225°	(107°)	-35°	(-37°)
	NBR	Buna-N	320°	(160°)	-40°	(-40°)
	FKM	Fluorocarbon Elastomer	400°	(205°)	-0°	(-17°)
Diaphragms	3-Ply	3-Ply TFE/FKM/TFE	400°	(205°)	0°	(-17°)
	BC	Neoprene (Polychloroprene)	250°	(121°)	-65°	(-53°)
	EPR	Ethylene Propylene	300°	(148°)	-40°	(-40°)
	FK	Fluorosilicone	350°	(177°)	-65°	(-54°)
	FKM	Fluorocarbon Elastomer	400°	(205°)	0°	(-17°)
	NBR	Buna-N (Nitrile)	250°	(121°)	-70°	(-56°)
	FKM+TFE	Fluorocarbon Elastomer + TFE	400°	(205°)	0°	(-17°)
Static Seals	RTFE	Bronze-filled TFE	425°	(218°)	70°	(21°)
	V-TFE	Virgin TFE	400°	(205°)	-325°	(-198°)
	EPR	Ethylene Propylene	300°	(148°)	-40°	(-40°)
	FK	Fluorosilicone	350°	(177°)	-65°	(-54°)
	FKM	Fluorocarbon Elastomer	400°	(205°)	-20°	(-28°)
	NBR	Buna-N	212°	(100°)	-40°	(-40°)
	SST/TFE	301/302 SST U-cup / TFE	400°	(205°)	-325°	(-198°)
	HC/TFE	Hastelloy C U-cup / TFE	400°	(205°)	-325°	(-198°)
Dynamic Seals	"PR"	Piston Ring Assy, GF-TFE / SST	425°	(218°)	-40°	(-40°)
	"PW"	PRA* w/Wiper, GF-TFE / SST / GF-TFE	425°	(218°)	70°	(21°)
	"CW" – EPR/TFE	TFE Cap Seal, EPR O-ring, GF-TFE Wiper	300°	(148°)	-40°	(-40°)
	"CW" – NBR/TFE	TFE Cap Seal, NBR O-ring, GF-TFE Wiper	212°	(100°)	-40°	(-40°)
	"CW" – FK/TFE	TFE Cap Seal, FK O-ring, GF-TFE Wiper	350°	(177°)	-40°	(-40°)
	"CW" – FKM/TFE	TFE Cap Seal, FKM O-ring, GF-TFE Wiper	400°	(205°)	-20°	(-28°)
	"CP" – EPR/TFE	TFE Cap Seal, EPR O-ring	300°	(148°)	-40°	(-40°)
	"CP" – NBR/TFE	TFE Cap Seal, NBR O-ring	212°	(100°)	-40°	(-40°)
	"CP" – FK/TFE	TFE Cap Seal, FK O-ring	350°	(177°)	-10°	(-23°)
	"CP" – FKM/TFE	TFE Cap Seal, FKM O-ring	400°	(205°)	-20°	(-28°)
	SST/TFE	301/302 SST U-cup / TFE	400°	(205°)	-325°	(-198°)
	HC/TFE	Hastelloy C U-cup / TFE	400°	(205°)	-325°	(-198°)
	ELG/TFE	Elgiloy / TFE U-cup	400°	(205°)	-325°	(-198°)

* PRA - Piston Ring Assembly

Metal Diaphragm		T Maximum		T Minimum	
ID	Description	°F	(°C)	°F	(°C)
BE-CU	Beryllium Copper	400°	(205°)	-325°	(-198°)

ABBREVIATIONS			
FK = Fluorosilicone	NBR = Buna-N	PTFE = Polytetrafluoroethylene	PRA = GF-TFE/SST
FKM = Fluorocarbon Elastomer	RTFE = Brz-fill TFE	V-TFE = Virgin TFE	BC = Neoprene
EPR = Ethylene Propylene	GF-TFE = Glass-fill TFE	CTFE = Chlorotrifluoroethylene TFE	ELG = Elgiloy

**TABLE DAG-6
REDUCER MAXIMUM CAPACITY WITH PLUG WIDE-OPEN**

Body Size		Full Port Max Capacity		Full Port Max Capacity	
in	(DN)	Cv	Kv	Cv	Kv
1/2"	(15)	4.0	3.4	3.5	3.0
3/4"	(20)	8.0	6.9	3.5	3.0
1"	(25)	15	13	3.5	3.0
1-1/4"	(32)	23	20	6.0	5.2
1-1/2"	(40)	30	26	6.0	5.2
2"	(50)	60	52	12	10.4
3"	(80)	120	104	X	
4"	(100)	220	190		
Diaphragm		Composition		Metal	
NOTE: The above Cv factors may be used for sizing of safety relief valves or rupture discs.					

**TABLE DAG-9
REDUCER – LOWER PISTON SPRING RANGES**

Basic Unit		Lower Piston Spring Range psig	Application Notes
Model	Diaphragm		
DA2	Comp	1-2	1-5 and 1-10 range spring only
DA2	Metal	4-10	–

- NOTES:**
1. All metallic diaphragm constructions MUST include a lower piston spring.
 2. The 1-2 psig lower piston spring should only be used with low pressure setpoints. (Psp ≤ 10 psig) and with composition diaphragms.
 3. Lower spring material matches main metallic trim in corrosion resistance.

**TABLE DAG-10
INBOARD LEAKAGE RATINGS *
Per ANSI/FCI 70-2**

Seat Material	Dynamic Seal	
	O-Ring	Dynamic Seals Except O-Ring
CTFE, GF-TFE, and V-TFE	IV	IV
BC, NBR, PolyAll, FKM	VI	IV
*Inboard leak rates are the composite leakage of the seat leakage + dynamic seal leakage, considered as a single inboard leakage value.		

**TABLE DAG-11
REDUCER RECOMMENDED VELOCITY LIMITS**

Application Fluid	Valve		Valve Body Outlet		Downstream Pipe		Units
	Type	Size Range	Recommend	Max.	Recommend	Max.	
Liquid	PRV	1/2"-4"	15	20	5-8	16	Ft/Sec
		6"	15	25	7-12	20	
		8"-12"	-	-	9-14	24	
Gas	PRV	1/2"-1"	0.20	0.40	0.15	0.30	Mach #
		1-1/4"-2"	0.25	0.45	0.20	0.30	
		2-1/2"-6"	0.30	0.50	0.25	0.35	
		8"-12"	-	-	0.25	0.40	
Steam	PRV	1/2"-1"	0.20	0.30	0.10	0.30	Mach #
		1-1/4"-2"	0.22	0.32	0.12		
		2-1/2"-6"	0.25	0.35	0.20		
		8"-12"	-	-	0.22		
NOTES: <ol style="list-style-type: none"> Liquids experiencing <u>no</u> 2-phase flow at valve outlet will have same valve body outlet velocity as inlet velocity. Liquids experiencing 2-phase flow at valve outlet should have average velocity less than 150-200 ft/sec. Liquids experiencing 2-phase flow at <u>outlet pipe</u> should have average velocity less than 20-50 ft/sec. If valve outlet exceeds recommended limits, then can use external sensing to reach maximum limits. On gas service, a pilot operated prv can work with a outlet Mach = 0.75. 							

**TABLE DAG 13
MAXIMUM RECOMMENDED NOISE LIMITS ***

Criteria	Body Sizes		Noise Level - dBA
	in	(DN)	
Per OSHA Regs. w/noise attenuation methods incorporated.	All	All	85-95
Sch. 80 pipe, no insulation.	1/2"-2"	(15-50)	95
Std. wt. pipe, no insulation.	2-1/2"-4"	(65-100)	98
* Consult Factory for <u>ALL</u> applications exceeding 97 dBA noise prediction.			

Schemes To Reduce High Noise –

- Staging – using two separate throttling valves in series.
- dB Plates – using 1, 2 or 3-stage dB Plate cartridges downstream of a throttling valve.
- Paralleling – using two separate throttling valves in parallel.
- Combinations – using multiple methods of above three possibilities.

TABLE DAG-14
RECOMMENDED INTERNAL MATERIALS
For P_{max}, Reference Individual Technical Bulletins

		LIQUIDS		
LIQUIDS	Fluid	Tmax °F	Tmin °F	Metal Trim
		Industrial Water – Cold	180°	32°
Hot		225°	32°	P4
	DI, DM	225°	32°	PJ
		250°	32°	PL
	Seawater	180°	-20°	MH
	Fuel Oils – Diesel, #1, #2‡	180°	-30°	P5
	Bunker C, #3 - #6‡	180°	-30°	P5
		400°	0°	PC
	Jet Fuel JP3, JP4, JP5, JP6‡	400°	0°	PC
	Kerosene‡	400°	0°	PC
	Crude Oils – Sweet‡	225°	0°	PA
		400°	0°	PC
	Sour‡	225°	0°	CF *
	Heat Transfer Oils – Dowtherm, Therminol, Mobil-Therm, Silvatherm	400°	0°	PC
	Misc. Oils – Lube Oil‡	180°	-30°	P5
	Naptha‡	400°	0°	PC
	Turbine Oil‡	225°	0°	PA
	Edible Oils – Vegetable Oil‡	180°	-30°	PH
	Animal Fats‡	180°	-30°	PH
	Seed Oils‡	180°	-30°	PH
	Inorganic Acids – Acetic - 5%	100°	0°	SL
	Acetic - 30%	100°	0°	SL
	Sulfuric - conc.	100°	0°	CF *
	Sulfuric - dilute	100°	0°	CF *
	Nitric - conc.	140°	0°	SL
Nitric - dilute	140°	0°	SL	
	Hydrofluoric (air free) - dilute, concentrate	100°	0°	CF *
	Hydrobromic	140°	0°	CF *
	Phosphoric - dilute, concentrate	150°	0°	SL
	Misc. Liquids – Gasoline‡	150°	-30°	P5
	Benzene (C ₆ H ₆)‡	150°	0°	SL
	Chlorine (Cl ₂)	150°	0°	ML
	Bromine (Br ₂)	150°	0°	CF *
	Ammonia (NH ₃)	140°	0°	SL
	Hydrogen Peroxide (H ₂ O ₂)	125°	0°	SL
	Hydrogen Chloride (HCl)	125°	0°	ML
Hydrogen Bromide (HBr)	125°	0°	SL	
Cane Sugar Liquor	180°	0°	PH	

‡ In accordance with ASME B31.3 "Process Piping", do not use Ductile Iron Body for hydrocarbon or flammable service with inlet pressures greater than 150 psig (10.3 Barg) or temperatures greater than 300 deg F (149 deg C).
* CF = Consult Factory

		GASES		
GASES	Fluid	Tmax °F	Tmin °F	Trim
	Atmospheric Gases	Atmospheric Gases – O₂ (GOX)	225°	-60°
350°			-65°	M9
350°			-325°	TN
N ₂ (GN ₂), Air, Argon		180°	-60°	P2
		350°	-65°	P8
CO ₂ (dry)		180°	-40°	P6
CO ₂ (wet)	180°	-40°	P5	
Process Gases	Process Gases – Nat. Gas (Sweet)	180°	-65°	P9
	Nat. Gas (Sour)	180°	-40°	CF *
	LPG (propane)	180°	-40°	PH
	Ammonia	120°	-40°	CF *
	Hydrogen	180°	-325°	SN
	Helium	180°	-325°	SN
	Chlorine (dry)	200°	0°	ME
	Hydrogen Chloride (dry)	120°	-40°	SJ
	Hydrogen Bromide (dry)	120°	0°	PE
	Hydrogen Fluoride (dry)	120°	0°	PE
	Hydrogen Sulfide (dry)	140°	0°	CF *
	Hydrogen Sulfide (wet)	140°	0°	CF *
	Sulfur Dioxide (dry)	120°	0°	PE
STEAM	P1 ≤ 125 psig	350°	—	PG

DAG-14 SUPPLEMENT CHEMICAL RESISTANCE

General Statement: Statements located within this technical bulletin concerning suitability of fluids with TFE materials are general statements, and should not be construed as recommendations. Any statements of suitability are the result of a compilation of various sources of information based on experience, tests, and published technical literature. No guarantee or warranty is in anyway implied for a given particular service or application.

Additional Reference: For an inclusive listing covering a broader range of service application fluids, reference "Handbook of Corrosion Resistant Piping", P.A. Schweitzer, Industrial Press or "Compass Corrosion Guide", 2nd Edition, K.M. Pruett, Compass Publications. This publication will include information based on the following fluid variables:

1. Solution concentration
2. Pressure
3. Temperature

DAG-15

Inverse Sympathetic Ratio (ISR) - effect on regulator performance.

DA2 regulators utilize a top and bottom guide, "flow to open" trim design. The top guide also acts as a "balancing" piston to oppose the forces generated by the inlet pressure acting on the valve plug. A small residual imbalance between the piston and the valve plug helps to reduce seat leakage at high differential pressures across the seat joint. This same imbalance produces an Inverse Sympathetic Ratio, ISR effect, as the delta pressure across the seat (DP) changes. The magnitude of the ISR effect is given in Table DAG-15 for both the pressure reducing and back pressure designs.

TABLE DAG-15		
Body Size		PRV - DA1/DA2/DA4/DAP
in	(DN)	
1/2", 3/4", 1"	(15,20,25)	0.03
1-1/4", 1-1/2"	(32,40)	0.04
2"	(50)	0.02
3", 4"	(80, 100)	0.054

A typical example of the ISR effect is the rise in outlet setpoint as the inlet pressure decays from a pressure vessel or compressed gas bottle. A 1" DA1 connected to a nitrogen bottle at 3000 psig can be adjusted to deliver downstream pressure, P2, of 100 psig. The P2 will rise to 181.48 psig as the compressed gas bottle pressure decays to 284 psig, because of the ISR effect. The calculation follows below:

$$P_{sp} = P_2 + (ISR \times \Delta P_1)$$

$$\Delta P_1 = \text{INITIAL INLET} - \text{FINAL INLET}. (3000 - 284) = 2716$$

$$P_2 = 100$$

$$ISR = 0.03 \text{ (1.0" DA1)}$$

$$P_{sp} = 100 + (0.03 \times 2716)$$

$$P_{sp} = 181.48$$

NOTE: For a rising DP across the seat, the ISR effect would cause a downward shift or offset in the setpoint.

If the ISR effect is unacceptable, then two regulators installed in series will greatly reduce the overall ISR effect. Overall ISR effect = ISR (first stage regulator) x ISR (second stage regulator). For example, in the same application of a N2 bottle source using two 1" DA1 regulators, the setpoint offset - 0.03 x 0.03 x 2716 = 2.44. In summary, the outlet pressure will rise from 100 psig to 102.44 psig as the inlet pressure decays from 3000 psig to 200 psig.

In a similar manner the ISR effect will produce an offset between the loading pressure, PL, and the pressure setpoint of a dome loaded regulator. For example, a 4" DA4 with an inlet pressure, P1 of 300 psig and an outlet pressure, P2 of 50 psig would require a loading pressure, PL = (P1 - P2) x ISR + P2 = (300-50) x 0.054 + 50 = 63.5 psig. In addition, if the DP changes, then a setpoint offset would be observed with a constant loading pressure.

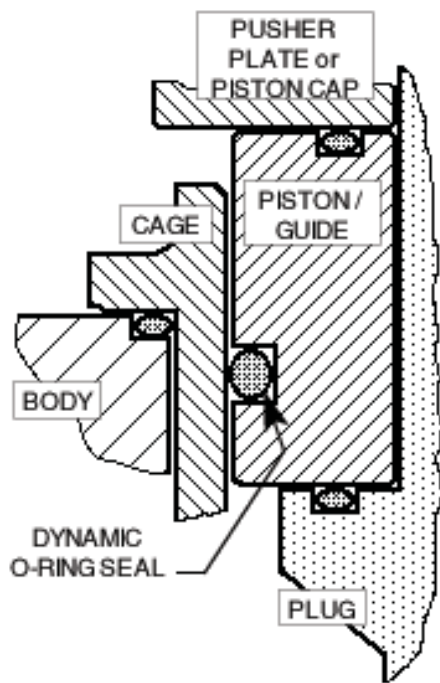

O-RING DYNAMIC SEAL

PRV, BPV

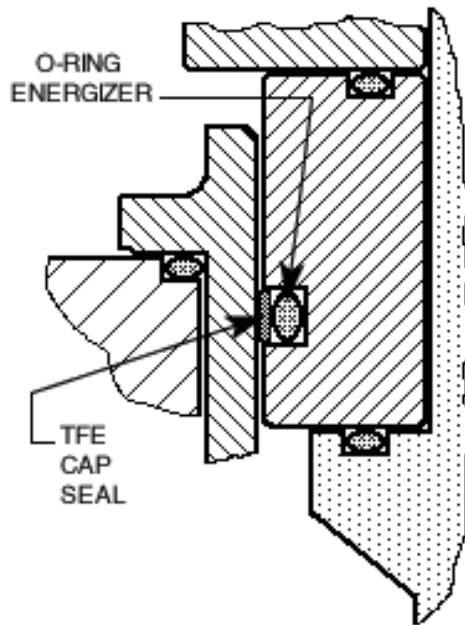

TFE CAP DYNAMIC SEAL

BPV

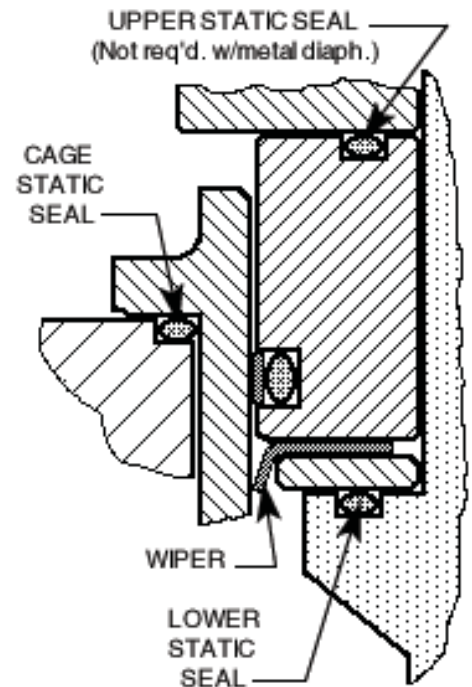

TFE CAP DYNAMIC SEAL + WIPER

PRV

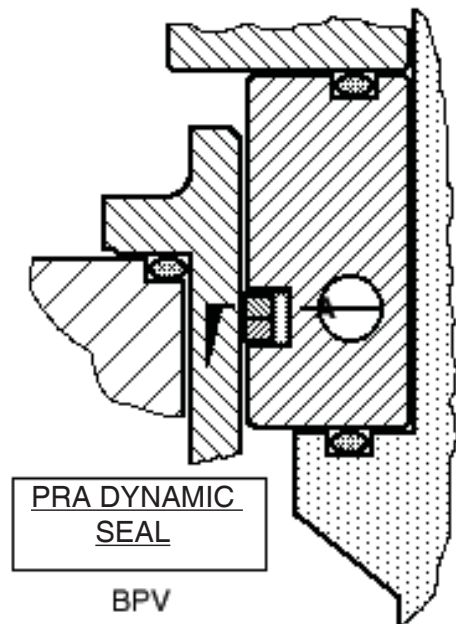

PRA DYNAMIC SEAL

BPV

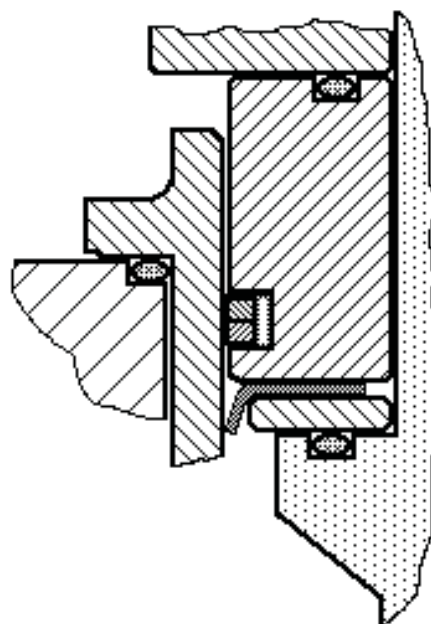

PRA DYNAMIC SEAL + WIPER

PRV

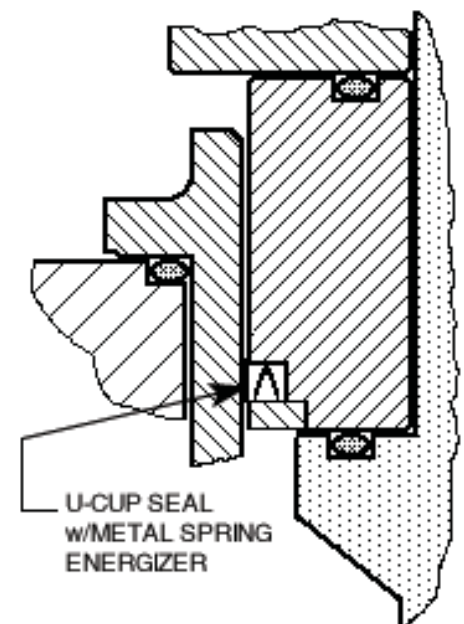

U-CUP DYNAMIC SEAL

PRV, BPV

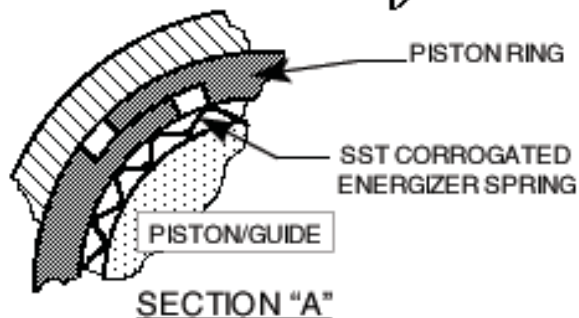

SECTION "A"

FIGURE DAG-F1
DYNAMIC & STATIC SEALS

FIGURE DAG-F2
Location of BODY / SPRING CHAMBER TAPS

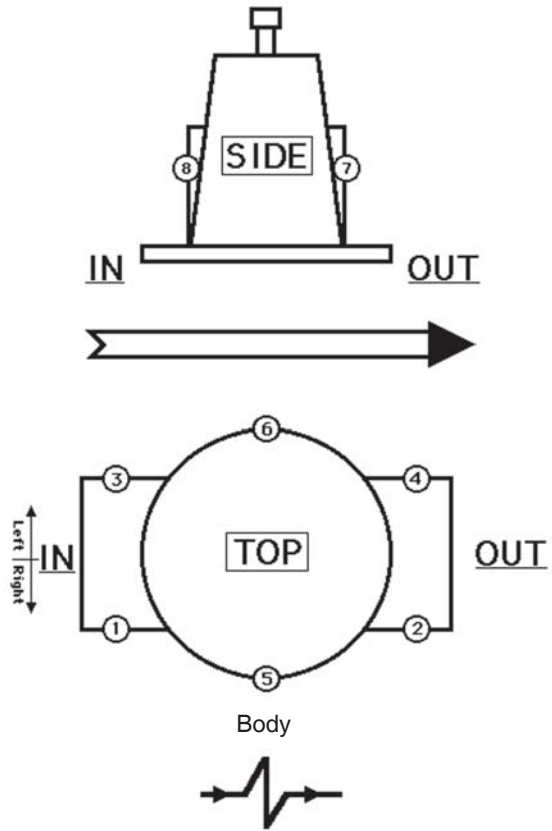

Flow To Open Direction

Location	Description	Opt. No.	NPT - Size	Body Mat'l.
1 & 2	Inlet & Outlet – Right	STD	1/4"	DI, CS & SST
1, 2 & 3	Inlet & Outlet – Right	STD	1/4"	BRZ
5	External Sensing – Right	STD	1/4"	ALL
1, 2, 3 & 4	Inlet & Outlet – Right Inlet & Outlet – Left	85	1/4"	ALL
5 & 6	Double External Sensing	85	1/4"	ALL

Location	Description	Opt. No.	NPT - Size	Sp. Ch. Mat'l.
7	Spring Ch. – Outlet Side	STD	1/4"	ALL
7 & 8	Double Spring Ch.	65A	1/4"	CS ONLY
	Double Spring Ch.	65B	1/2"	
	Double Spring Ch.	65C	3/4"	
	Double Spring Ch.	65D	1"	

DIMENSION and WEIGHTS

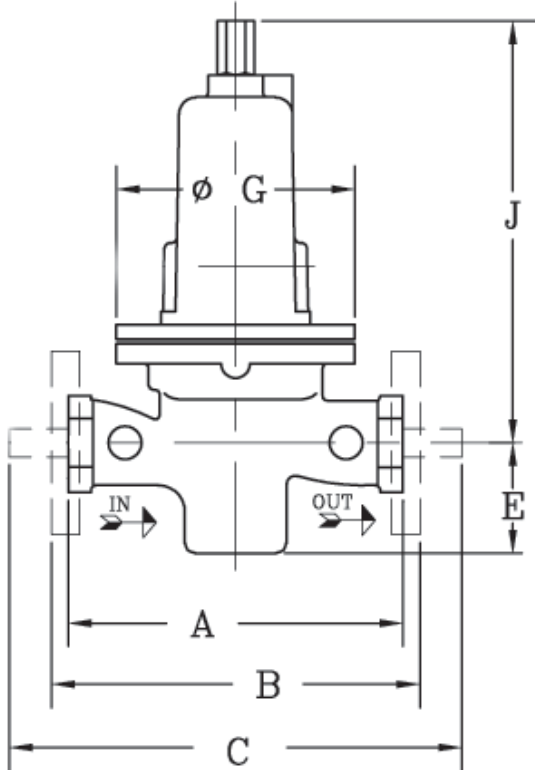

ENGLISH UNITS (in) (lbs)

METRIC UNITS (mm) (kg)

DIMEN.	END CONN.	BODY MAT'L	BODY SIZE				
			1/2", 3/4" & 1"	1-1/4" & 1-1/2"	2"	3"	4"
A	NPT	DI, BRZ	6.00	9.88	9.88	-	-
		CS, SST	8.25	9.88	9.75	-	-
B	125# FF	DI	-	-	-	11.75	13.88
	250# RF	DI	-	-	-	12.50	14.50
	150# FF	BRZ **	9.63	11.50 ✓	11.50	11.75	13.88
	300# FF	BRZ **	9.63	11.50 ✓	11.50	12.15	14.50
	150# RF	CS, SST	10.75	12.38 ✓	10.00	11.75	13.88
	150# RF ‡	CS, SST	14.00	14.00 ✓	14.00	-	-
	300# RF	CS, SST	10.75	12.38 ✓	10.50	12.50	14.50
	300# RF ‡	CS, SST	14.00	14.00 ✓	14.00	-	-
	600# RF	CS, SST	10.75	12.38 ✓	11.25	13.25	15.50
	600# RF ‡	CS, SST	14.00	14.00 ✓	14.00	-	-
C	OPT-32 EXT NIPS	CS, SST	14.00	15.75	15.75	-	-
	OPT-41	SST	11.00	15.25	15.50	-	-
E	ALL	ALL	2.84	3.69	4.00	5.75	7.00
G	ALL	ALL	6.00	7.00	8.00	11.00	11.13
J	ALL	ALL	10.13	12.63	13.00	23.00	23.50
WEIGHT	wo/ Flanges	ALL	23	33	39	-	-
	w/Flanges	ALL	28	43	52	175	190

END CONN.	BODY SIZE					
	DN15, DN20 & DN25	DN32 & DN40	DN50	DN80	DN100	
NPT	125# FF	-	-	-	298	352
	250# RF	-	-	-	318	368
150# FF	150# FF	246	292 ✓	292	298	352
	300# FF	246	292 ✓	292	309	368
150# RF	150# RF	273	314 ✓	254	298	352
	150# RF ‡	356	356 ✓	356	-	-
300# RF	300# RF	273	314 ✓	267	318	368
	300# RF ‡	356	356 ✓	356	-	-
600# RF	600# RF	273	314 ✓	286	336	394
	600# RF ‡	356	356 ✓	356	-	-
OPT-32 EXT NIPS	OPT-32 EXT NIPS	356	400	400	-	-
	OPT-41	279	387	394	-	-
ALL	ALL	72	94	102	146	178
	ALL	152	178	203	279	283
ALL	ALL	257	321	330	584	597
	ALL	257	321	330	584	597
wo/ Flanges	wo/ Flanges	11	16	18	-	-
	w/Flanges	13	20	24	79	86

** Flanged BRZ bodies available in sizes 1", 1-1/2", 2", 3", & 4" ONLY.
 ✓ Flange Connections not available for 1-1/4" size.
 ‡ Opt-34: Special 14" F to F Flange dimensions, CS and SST body material only.
 Consult Factory for dimensions of ISO DIN Flanged units. (PN16, PN25, PN40)

The contents of this publication are presented for informational purposes only, and while every effort has been made to ensure their accuracy, they are not to be construed as warranties or guarantees, express or implied, regarding the products or services described herein or their use or applicability. We reserve the right to modify or improve the designs or specifications of such product at any time without notice. Cashco, Inc. does not assume responsibility for the selection, use or maintenance of any product. Responsibility for proper selection, use and maintenance of any Cashco, Inc. product remains solely with the purchaser.

MODEL DA2 PRODUCT CODER 03/14/16

An "X" in POS 12 followed by a 5-digit control number overrides remaining selections.

D2 POS 3 — POS 5 POS 6 & 7 POS 8 — POS 10 POS 11 POS 12 **0** POS 14 POS 15 POS 16 POS 17 **E**

POSITION 3 SIZES & DIAPHRAGM CONSTRUCTION			
Body Size		Diaphragm Support	
in	(DN)	STD	FULL OPT-81
		CODE	CODE
1/2"	(15)	4	J
3/4"	(20)	5	K
1"	(25)	6	L
1-1/4"	(32)	7	M
1-1/2"	(40)	8	N
2"	(50)	9	P
3" ^	(80)	B	NA
4" ^	(100)	C	NA

^ Not available with metal diaphragms.
NA Not Available

POSITION 5 BODY & SPRING CHAMBER MATERIALS			
Materials	CODE	Materials	CODE
DI/DI	1	CS/CS *√	5
BRZ/DI	2	LCC/LCC */**	6
BRZ/BRZ ‡	B	LCC/SST *	8
BRZ/CS √	J	SST/DI	7
BRZ/SST	D	SST/CS *√	9
CS/DI	4	SST/SST *	A

* For Opt-81 Select CS, LCC or SST Spring Chamber Material except in Canada, use SST. See Table 1. NOTE: (CS Spg Chmb Mat'l in Sizes 3"-4" not registered for shipment into Canada.)
**LCC Mat'l not available in 3" - 4".
‡ Sizes 1/2" - 2"

POSITION 6 & 7 - DIAPHRAGM, SEAL & SEAT MATERIALS					
Trim	Seat	Diaphragm	Static Seal	Dynamic Seal	CODE
17-4PH SST "P"	PA	BC	NBR	O-ring	P1
	PA / (BC)	BC	NBR	SST/TFE u-cup	P2 / (PU)
	CTFE	BC	NBR	SST/TFE u-cup	P3
	PA	EPR	EPR	O-ring	P4
	PA	NBR	NBR	O-ring	P5
	PA / (NBR)	NBR	NBR	SST/TFE u-cup	P6 / (PW)
	PA	FK	FK	SST/TFE u-cup	P7 ‡
	GF-TFE	FK	FK	SST/TFE u-cup	P8 ‡
	V-TFE	FK	FK	SST/TFE u-cup	P9 ‡
	PA	FKM	FKM	O-ring	PA
	PA	FKM	FKM	SST/TFE u-cup	PB
	GF-TFE	FKM	FKM	O-ring	PC
	GF-TFE	FKM	FKM	SST/TFE u-cup	PD
	V-TFE	FKM + TFE	SST/TFE u-cup √	SST/TFE u-cup	PE
	GF-TFE	3-ply	RTFE	SST/TFE u-cup \$	PF
	GF-TFE	3-ply	RTFE	PRA + W \$	PG
	PA / (NBR)	NBR	NBR	TFE+NBR GFTFE CW	PH / (PY)
	PA	EPR	EPR	TFE+EPR GFTFE CW	PJ
	PA	FK	FK	TFE+FK GFTFE CW	PK
	GF-TFE	FKM	FKM	TFE+FKM GFTFE CW	PL
FKM	FKM	FKM	SST/TFE u-cup	PZ	
Monel "M"	PA	FK	FK	SST/TFE u-cup ‡	M7 ‡
	V-TFE	FK	FK	SST/TFE u-cup	M9 ‡
	V-TFE	FKM-TFE	SST/TFE u-cup √	SST/TFE u-cup	ME
	PA / (NBR)	NBR	NBR	TFE+NBR GFTFE CW	MH / (MY)
	PA	EPR	EPR	TFE+EPR GFTFE CW	MJ
	PA	FK	FK	TFE+FK GFTFE CW	MK
	GF-TFE	FKM	FKM	TFE+FKM GFTFE CW	ML
	FKM	FKM	FKM	SST/TFE u-cup	MZ
	PA	FK	FK	SST/TFE u-cup	S7 ‡
	V-TFE	FK	FK	SST/TFE u-cup	S9 ‡
316L SST "S"	PA	BE-CU *	SST/TFE u-cup	SST/TFE u-cup	SM
	V-TFE	BE-CU *	SST/TFE u-cup	SST/TFE u-cup	SN
	PA / (NBR)	NBR	NBR	TFE+NBR GFTFE CW	SH / (SY)
	PA	EPR	EPR	TFE+EPR GFTFE CW	SJ
	PA	FK	FK	TFE+FK GFTFE CW	SK
17-4PH/ Monel/ 17-4PH "T"	GF-TFE	FKM	FKM	TFE+FKM GFTFE CW	SL
	PA	FK	FK	SST/TFE u-cup ‡	T7 ‡
	V-TFE	FK	FK	SST/TFE u-cup	T9 ‡
	PA	BE-CU *	SST/TFE u-cup	SST/TFE u-cup	TM
	V-TFE	BE-CU *	SST/TFE u-cup	SST/TFE u-cup	TN
PA	FK	FK	TFE+FK GFTFE CW	TK	

‡ For GOX service, PA seats allowed in BRZ Bodies w/ trim materials "M" or "T" only.
* 3" - 4" sizes are not available with metal diaphragm.
‡ For Low Ambient Temperatures (See DAG-5 & -14 for Min. Temperatures).
√ Sizes 3"-4" use V-TFE static seal.
\$ For Steam Applications Max Press < 125 psig.
Abbreviations defined on page 2.

POSITION 8 - Product Classification Under European Pressure Equipment Directive		
PRODUCT DESTINATION	HAZARD CATEGORY	CODE
Anywhere except Europe	N/A	7
European Countries * (CE Mark does not apply to DN25 and below)	Sound Engineering Practice (SEP)	S
	CE Marked Hazard Cat I or II	E

* For products to be placed in service in Europe - Ref to Directive 97/23/EC. Forward Completed "EU" Application Recorder prior to quotation. (Without Recorder-Processing of Purchase Order will be delayed). Contact Cashco for Assistance.

POSITION 10 - END CONNECTIONS / ASME								
Size	Material	Method	End Conn	CODE	End Conn	CODE	End Conn	CODE
1/2" - 2"	ALL	-	NPT	1	-	-	-	-
3" - 4"	DI	Integral	125#FF	2	250#RF	3	-	-
1", 1-1/2" - 4"	BRZ	Integral	150#FF	6	300#FF	7	-	-
1/2" - 3/4"	CS,SST	Opt-30	150#RF	4	300#RF	5	600# RF	8
1" - 4"	CS-SST	Integral *	150#RF	4	300#RF	5	600# RF	**
1/2" - 2"	ALL	Opt-31	BSP	P	-	-	-	-
1/2" - 2"	CS, SST	Opt-32	Extended Nipples		E	-	-	-
1/2" - 2" (14" F to F)	CS, SST	Opt-34 *	150#RF	V	300#RF	W	600#RF	Y
1/2" - 1", 1-1/2" - 2"	SST	Opt-41	Non-High Purity Tube Ends		T	-	-	-

END CONNECTIONS FOR ISO DIN FLANGES								
DN15-25, 40, 50	BRZ	Integral	PN40 FF - will mate with PN16, 25 and 40					
DN80-100			PN16 FF	K	PN25 FF	L	PN40 FF	M
DN15-25, 40, 50	CS, SST, HC	Opt-30	PN40 RF - will mate with PN16, 25 and 40			D		
DN80-100	CS, SST	Integral	PN16 RF	A	PN25 RF	C	PN40 RF	G

* Flanges Not Available for 1-1/4" (DN32) size.
** 1" size w/ 600# RF CS, or SST has weld-on flanges Opt-30.

POSITION 11 - RANGE SPRINGS							
Body Size	Pressure Range		CODE	Body Size	Pressure Range		CODE
	psid	bard			psid	bard	
1/2" 3/4" 1" (DN15, 20 & 25)	1-5 ^	.07-.34	1	2" (DN50)	1-5 ^	.07-.34	1
	1-10 *	.07-.68	S		1-10 *	.07-.68	S
	5-20	.34-1.3	A		5-15	.34-1.0	M
	10-35	.68-2.4	B		10-30	.68-2.0	N
	20-80	1.3-5.5	C		15-50	1.0-3.4	P
	30-150	2.0-10.3	D		30-90	2.0-6.2	Q
1-1/4" 1-1/2" (DN32 & 40)	70-200	4.8-13.7	E	3" & 4" (DN 80 & 100)	1-10	.07-.68	S
	1-5 ^	.07-.34	1		5-20	.34-1.3	A
	1-10 *	.07-.68	S		10-40	.68-2.7	T
	5-20	.34-1.3	A		10-70	.68-4.8	J
	15-45	1.0-3.1	H		40-125	2.7-8.6	K
	10-70	.68-4.8	J				

^ Composition diaphragm construction ONLY
* Metal Diaphragm for P_{sp} ≥ 5 psid. (.34Bard)

POSITION 12 - SENSING FLOW DIRECTION	
Option	Flow To Open
	CODE
Internal	1
External	2
Large Internal	4
For Special Construction Contact Cashco for Special Code	X

POSITION 14 - SPRING CHAMBER OPTIONS		
Description	Option	CODE
Std Flow-thru connections 1/4"	-65A	F
Flow-thru Spring Chamber, 1/2" NPT CS Material ONLY.	-65B	G
Flow-thru Spring Chamber, 3/4" NPT CS Material ONLY.	-65C	H
Flow-thru Spring Chamber, 1" NPT CS Material ONLY.	-65D	K

POSITION 15 - BODY OPTIONS		
Description	Option	CODE
No Option	-	0
Second "SET" of 1/4" (DN8) FNPT Pressure Taps & Plugs.	-85	T

POSITION 16 - CERTIFICATE OPTIONS		
Description	Option	CODE
No Option	-	0
SPECIAL CLEANING: Per Cashco Spec #S-1134. W/ properly selected mat'ls. Suitable for Oxygen Service. BRZ or SST body material.	-55	M
SPECIAL CLEANING: Per Cashco Spec #S-1542.	-56	N
SPECIAL CLEANING: Per Cashco Spec #S-1589 Cl ₂ Service.	-57	P

POSITION 17 - PAINT OPTIONS		
Description	Option	CODE
No Option	-	0
Epoxy Painted Per Cashco Spec #S-1547.	-95	W
Epoxy Painted Per Cashco Spec #S-1687 OFFSHORE Applic.	-95OS	Y

Cashco, Inc.
P.O. Box 6
Ellsworth, KS 67439-0006
PH (785) 472-4461
Fax. # (785) 472-3539
www.cashco.com
email: sales@cashco.com
Printed in U.S.A.

Cashco GmbH
Handwerkerstrasse 15
15366 Hoppegarten, Germany
PH +49 3342 30968 0
Fax. No. +49 3342 30968 29
www.cashco.com
email: germany@cashco.com

Cashco do Brasil, Ltda.
Al.Venus, 340
Indaiatuba - Sao Paulo, Brazil
PH +55 11 99677 7177
Fax. No.
www.cashco.com
email: brazil@cashco.com