

Precision Pressure Controller/Calibrator

High pressure calibrations up to 1000 bar gauge pressure

DPC 3800 HD

Applications

- Calibration laboratories
- Service industries and calibration services
- Laboratories for research and development
- Pressure gauge, pressure switch and sensor manufacturing resp. transmitter calibration and creation of certificates
- Long-term measurement
- Aerospace industry

Specialties

Pressure Range

Gauge pressure: 0 – 400 bar to 0 – 1,000 bar
(0 – 5,000 psi to 0 – 15,000 psi)

Measurement uncertainty (k = 2): 0.01 % FS

- Medium water or oil
- Pressure controller with precision pressure sensor
- Customized configurations of the pressure controller possible
- Very high measuring rate
- Colour touchscreen, LED backlight
- Easily calibrated
- Modular construction
- Fully digital measuring instrument
- Automatic generation of test certificates with optional calibration software DynaCal

Description

Functionality

This instrument stands out due to its precision sensor, that combines maximum precision with highest long-term stability. The DPC 3800 HD achieves a control stability of 0.003 % of the pressure range.

The instrument is operated intuitively via touchscreen. All extended functions are accessible via submenus.

Software

Besides the optionally available calibration software DynaCal, which allows for comfortable calibration of pressure measuring instruments, including automatic generation of test certificates, the user is able to create own software programmes, e.g. via LabVIEW®.

Communication

For integration in already existing infrastructures a RS-232, ethernet, or optionally IEEE-488.2 interface or an analogue output is available. Customer-specific control commands can be translated.

Complete Testing and Calibration Systems

Completely mobile or stationary test benches can be manufactured upon request.



Technical Data

	Pressure Ranges	
Gauge pressure	0 – 400 bar	0 – 5,000 psi
	0 – 600 bar	0 – 8,000 psi
	0 – 1,000 bar	0 – 15,000 psi

Pressure Units 23 and 1 freely programmable

Instrument Version table-top housing and hydraulic cabinet, further options see back of page

Dimensional Data see back of page

Weight approx. 7.0 kg (15.43 lb)
+ 45 kg (99.2 lb) hydraulic cabinet

Display

Screen division: actual value, reference value, steps
Resolution: 6 digits
Keyboard: colour touchscreen
Warm-up time: < 10 minutes
Response time: approx. 10 ms

Pressure Range 1 pressure range

Pressure Connections

M 16x1.5 high pressure screw fitting
optional: G ½ quick clamp adapter

Medium

Water as standard, optional: oil

Overrange protection

140 % of the pressure range
optional: mechanical overpressure protection

Power Supply

Auxiliary energy 88 – 264 V AC, 47 – 63 Hz

Compressed Air Supply

≥ 10 bar



Sales and Export South, West, North

ARMATURENBAU GmbH

Manometerstraße 5 • D – 46487 Wesel-Ginderich
Tel.: +49 2803 9130 – 0 • Fax: +49 2803 1035
armaturenbau.com • mail@armaturenbau.com

Subsidiary Company, Sales and Export East

MANOTHERM Beierfeld GmbH

Am Gewerbepark 9 • D – 08344 Grünhain-Beierfeld
Tel.: +49 3774 58 – 0 • Fax: +49 3774 58 – 545
manotherm.com • mail@manotherm.com

10462

05/16

Technical Data (continued from page 1)

Permissible Ambient Conditions

Operating temperature: +10 °C to +40 °C (+50 °F to +104 °F)
 Storage temperature: 0 °C to +70 °C (+32 °F to +158 °F)
 consider frost protection when water is the pressure medium

Relative humidity: 0 to 95 % r. h. (non-condensing)
 Compensated temperature range: +15 °C to +35 °C (+59 °F to +95 °F)

Communication

Interfaces: RS-232, Ethernet

Optional

Interface: IEEE-488.2
 Analogue output: 0 – 1 V; 0 – 5 V; 0 – 10 V or 4 – 20 mA (16 bit)
 Switching outputs: 24 V DC PWM or TTL level
 Analogue inputs: 4 – 20 mA or 0 – 10 V, others upon request

Instruction Sets

DPC 3800 HD, alternative instruction sets possible, alignment to existing HOST software upon request

Approvals and Certificates

EMC-directive 2004 / 108 / EG, DIN EN 61 326-1 emission (group 1, class A) and stability (industrial sector);

Calibration certificate 3.1 according to DIN EN 10204, optional internationally traceable calibration certificate (e.g. DAkkS)

Dimensional Data in mm / inch

Recommended Instrument Version: Calibration Work Station

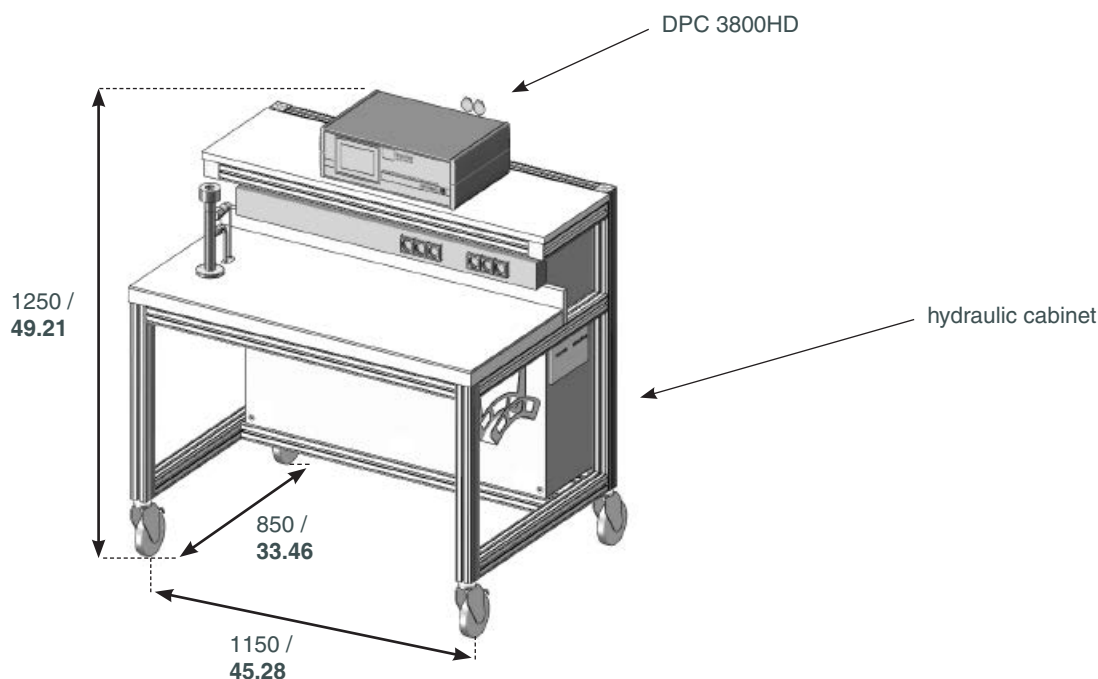

Further Options

The DPC 3800 HD has 4 switching outputs that can be used for options. Furthermore, up to four precision sensors can be actuated.

Option M

The following features were integrated

- On and off switch for a vacuum pump
- Internal separation of regulator and test item
- An additional ventilation valve for the test item side

This option is suitable, for example, for pressure gauge adjustment.

Option Vac

With this option, a 24 V signal can be actuated, in order to switch a vacuum pump on or off, for example.

Calibration Work Station

Extensions of the standard version

- 1 work bench
- 1 desk with wheels
- 1 complete high pressure piping

Scope of Delivery (Basic Equipment)

- Precision pressure controller / calibrator in table-top housing
- Hydraulic cabinet
- Mains cable 1.5 m
- Operating instruction
- Calibration certificate 3.1 according to DIN EN 10204

Ordering Information

Model DPC 3800 HD, 1 pressure range, options if required